

**DEWALT®**

**DWE8410**

**DWE8420**

**DWE8411**

**DWE8421**

**[www.DEWALT.com](http://www.DEWALT.com)**



Fig. A-1

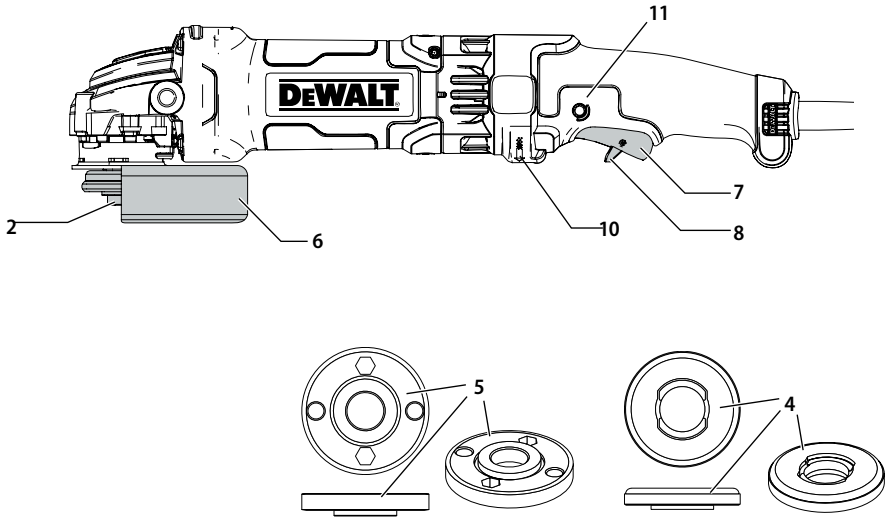

Fig. A-2

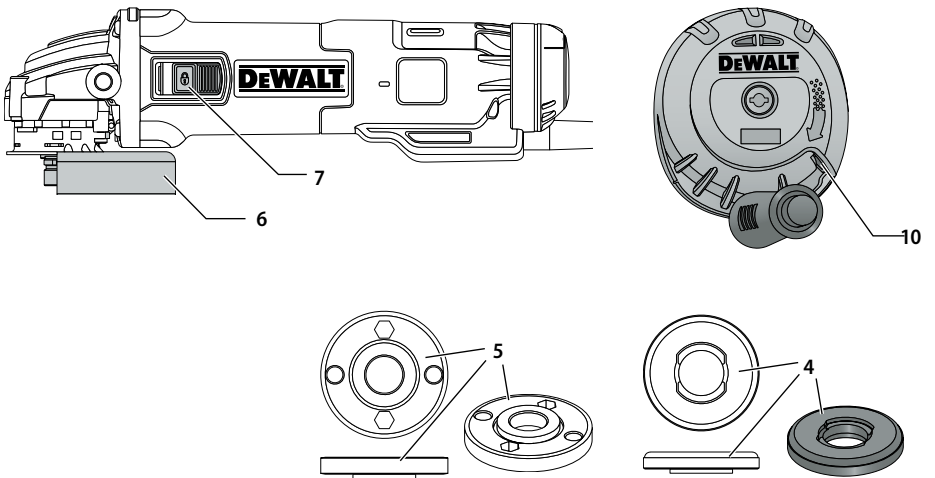

Fig. B

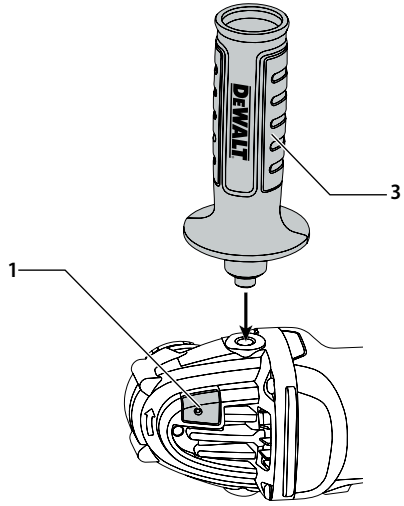

Fig. C

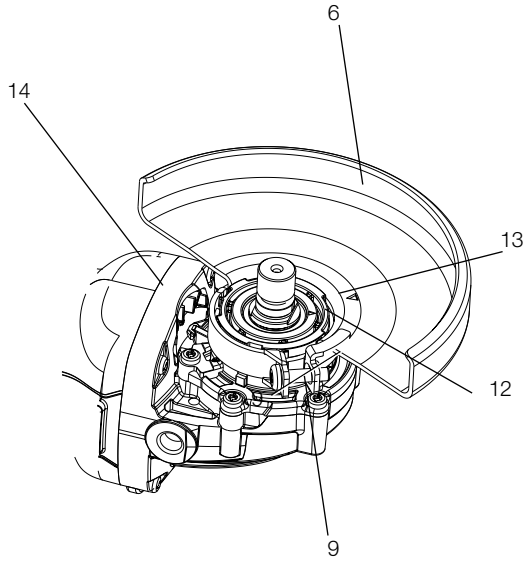

Fig. D-1

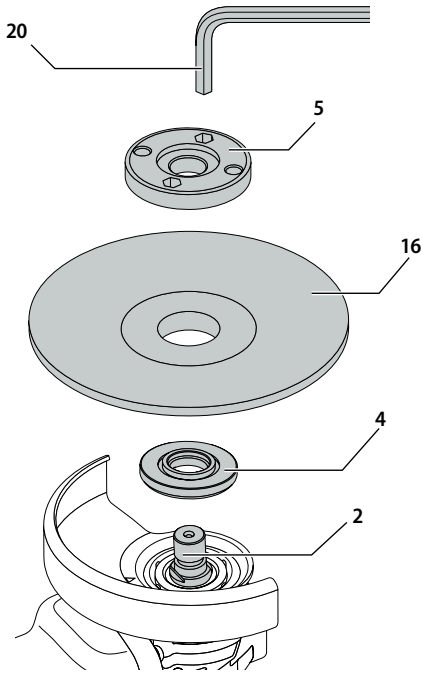

Fig. D-2

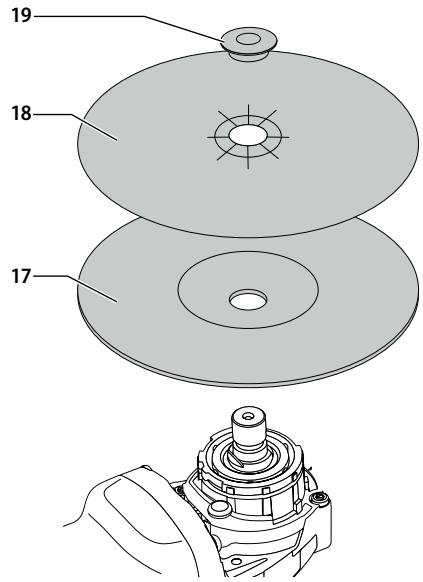

Fig. G-1

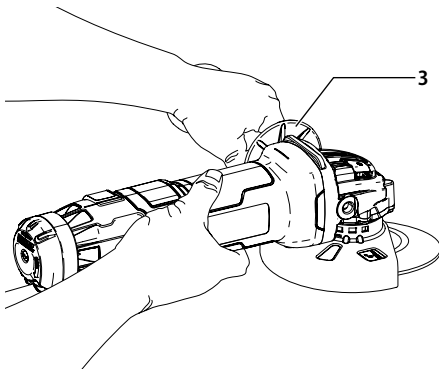
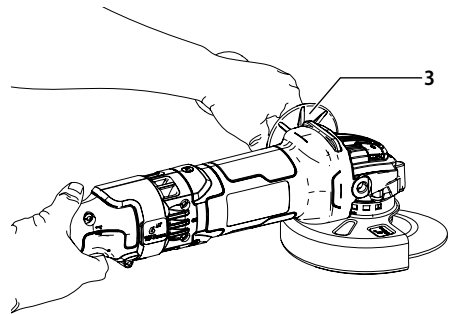

Fig. G-2



# SMALL ANGLE GRINDERS

## DWE8410,DWE8420,DWE8411

### Congratulations!

You have chosen a DEWALT tool. Years of experience, thorough product development and innovation make DEWALT one of the most reliable partners for professional power tool users.

### Technical Data

		DWE8410	DWE8420	DWE8411
Voltage	V <sub>ac</sub>	220-240	220-240	220-240
Power input	W	1400	1400	1400
rated speed	r/min	10500	9500	10500
Wheel diameter	mm	125	150	125
Wheel thickness (max)	mm	6.0	6.0	6.0
Spindle diameter		M14	M14	M14
Spindle length	mm	18.5	18.5	18.5
Weight	kg	2.5*	2.5*	2.5*

\* weight includes side handle and guard

### Definitions: Safety Guidelines

The definitions below describe the level of severity for each signal word. Please read the manual and pay attention to these symbols.



**DANGER:** Indicates an imminently hazardous situation which, if not avoided, **will** result in **death or serious injury**.



**WARNING:** Indicates a potentially hazardous situation which, if not avoided, **could** result in **death or serious injury**.



**CAUTION:** Indicates a potentially hazardous situation which, if not avoided, **may** result in **minor or moderate injury**.

**NOTICE:** Indicates a practice **not related to personal injury** which, if not avoided, **may** result in **property damage**.



Denotes risk of electric shock.



Denotes risk of fire.

### General Power Tool Safety Warnings



**WARNING:** Read all safety warnings and all instructions. Failure to follow the warnings and instructions may result in electric shock, fire and/or serious injury.

### SAVE ALL WARNINGS AND INSTRUCTIONS FOR FUTURE REFERENCE

The term "power tool" in the warnings refers to your mains-operated (corded) power tool or battery-operated (cordless) power tool.

### Work area safety

- Keep work area clean and well lit.** Cluttered or dark areas invite accidents.
- Do not operate power tools in explosive atmospheres, such as in the presence of flammable liquids, gases or dust.** Power tools create sparks which may ignite the dust or fumes.
- Keep children and bystanders away while operating a power tool.** Distractions can cause you to lose control.

### Electrical safety

- Power tool plugs must match the outlet. Never modify the plug in any way. Do not use any adapter plugs with earthed (grounded) power tools.** Unmodified plugs and matching outlets will reduce risk of electric shock.
- Avoid body contact with earthed or grounded surfaces such as pipes, radiators, ranges and refrigerators.** There is an increased risk of electric shock if your body is earthed or grounded.
- Do not expose power tools to rain or wet conditions.** Water entering a power tool will increase the risk of electric shock.
- Do not abuse the cord. Never use the cord for carrying, pulling or unplugging the power tool. Keep cord away from heat, oil, sharp edges or moving parts.** Damaged or entangled cords increase the risk of electric shock.
- When operating a power tool outdoors, use an extension cord suitable for outdoor use.** Use of a cord suitable for outdoor use reduces the risk of electric shock.

- i) **If operating a power tool in a damp location is unavoidable, use a residual current device (RCD) protected supply.** Use of an RCD reduces the risk of electric shock.
- u) **Maintain power tools. Check for misalignment or binding of moving parts, breakage of parts and any other condition that may affect the power tool's operation. If damaged, have the power tool repaired before use.** Many accidents are caused by poorly maintained power tools.

## Personal safety

- j) **Stay alert, watch what you are doing and use common sense when operating a power tool. Do not use a power tool while you are tired or under the influence of drugs, alcohol or medication.** A moment of inattention while operating power tools may result in serious personal injury.
- k) **Use personal protective equipment. Always wear eye protection.** Protective equipment such as dust mask, non-skid safety shoes, hard hat, or hearing protection used for appropriate conditions will reduce personal injuries.
- l) **Prevent unintentional starting. Ensure the switch is in the off position before connecting to power source and/or battery pack, picking up or carrying the tool.** Carrying power tools with your finger on the switch or energising power tools that have the switch on invites accidents.
- m) **Remove any adjusting key or wrench before turning the power tool on.** A wrench or a key left attached to a rotating part of the power tool may result in personal injury.
- n) **Do not overreach. Keep proper footing and balance at all times.** This enables better control of the power tool in unexpected situations.
- o) **Dress properly. Do not wear loose clothing or jewellery. Keep your hair, clothing and gloves away from moving parts.** Loose clothes, jewellery or long hair can be caught in moving parts.
- p) **If devices are provided for the connection of dust extraction and collection facilities, ensure these are connected and properly used.** Use of dust collection can reduce dust-related hazards.
- v) **Keep cutting tools sharp and clean.** Properly maintained cutting tools with sharp cutting edges are less likely to bind and are easier to control.
- w) **Use the power tool, accessories and tool bits etc., in accordance with these instructions taking into account the working conditions and the work to be performed.** Use of the power tool for operations different from those intended could result in a hazardous situation.

## Service

- x) **Have your power tool serviced by a qualified repair person using only identical replacement parts.** This will ensure that the safety of the power tool is maintained.

## ADDITIONAL SPECIFIC SAFETY RULES

### Safety Instructions for All Operations

- a) **This power tool is intended to function as a grinder, sander, wire brush or cut-off tool. Read all safety warnings, instructions, illustrations and specifications provided with this power tool.** Failure to follow all instructions listed below may result in electric shock, fire and/or serious injury.
- b) **Operations such as polishing are not recommended to be performed with this power tool.** Operations for which the power tool was not designed may create a hazard and cause personal injury.
- c) **Do not use accessories which are not specifically designed and recommended by the tool manufacturer.** Just because the accessory can be attached to your power tool, it does not assure safe operation.
- d) **The rated speed of the accessory must be at least equal to the maximum speed marked on the power tool.** Accessories running faster than their rated speed can break and fly apart.
- e) **The outside diameter and the thickness of your accessory must be within the capacity rating of your power tool.** Incorrectly sized accessories can not be adequately guarded or controlled.
- f) **Threaded mounting of accessories must match the grinder spindle thread. For accessories mounted by flanges, the arbour hole of the accessory must fit the locating diameter of the flange.** Accessories that do not match the mounting hardware of the power tool will run out of balance, vibrate excessively and may cause loss of control.
- g) **Do not use a damaged accessory. Before each use inspect the accessory such as abrasive wheel for chips and cracks, backing pad for cracks, tear or excess wear, wire brush for loose or cracked wires.**

## Power tool use and care

- q) **Do not force the power tool. Use the correct power tool for your application.** The correct power tool will do the job better and safer at the rate for which it was designed.
- r) **Do not use the power tool if the switch does not turn it on and off.** Any power tool that cannot be controlled with the switch is dangerous and must be repaired.
- s) **Disconnect the plug from the power source and/or the battery pack from the power tool before making any adjustments, changing accessories, or storing power tools.** Such preventive safety measures reduce the risk of starting the power tool accidentally.
- t) **Store idle power tools out of the reach of children and do not allow persons unfamiliar with the power tool or these instructions to operate the power tool.** Power tools are dangerous in the hands of untrained users.

*If power tool or accessory is dropped, inspect for damage or install an undamaged accessory. After inspecting and installing an accessory, position yourself and bystanders away from the plane of the rotating accessory and run the power tool at maximum no-load speed for one minute. Damaged accessories will normally break apart during this test time.*

- h) **Wear personal protective equipment. Depending on application, use face shield, safety goggles or safety glasses. As appropriate, wear dust mask, hearing protectors, gloves and workshop apron capable of stopping small abrasive or workpiece fragments.** *The eye protection must be capable of stopping flying debris generated by various operations. The dust mask or respirator must be capable of filtering particles generated by your operation. Prolonged exposure to high intensity noise may cause hearing loss.*
- i) **Keep bystanders a safe distance away from work area. Anyone entering the work area must wear personal protective equipment.** *Fragments of workpiece or of a broken accessory may fly away and cause injury beyond immediate area of operation.*
- j) **Hold the power tool by insulated gripping surfaces only, when performing an operation where the cutting accessory may contact hidden wiring or its own cord.** *Cutting accessory contacting a "live" wire may make exposed metal parts of the power tool "live" and could give the operator an electrical shock.*
- k) **Position the cord clear of the spinning accessory.** *If you lose control, the cord may be cut or snagged and your hand or arm may be pulled into the spinning accessory.*
- l) **Never lay the power tool down until the accessory has come to a complete stop.** *The spinning accessory may grab the surface and pull the power tool out of your control.*
- m) **Do not run the power tool while carrying it at your side.** *Accidental contact with the spinning accessory could snag your clothing, pulling the accessory into your body.*
- n) **Regularly clean the power tool's air vents.** *The motor's fan will draw the dust inside the housing and excessive accumulation of powdered metal may cause electrical hazards.*
- o) **Do not operate the power tool near flammable materials.** *Sparks could ignite these materials.*
- p) **Do not use accessories that require liquid coolants.** *Using water or other liquid coolants may result in electrocution or shock.*
- q) **Do not use Type 11 (flaring cup) wheels on this tool.** *Using inappropriate accessories can result in injury.*
- r) **Always use side handle. Tighten the handle securely.** *The side handle should always be used to maintain control of the tool at all times.*

## FURTHER SAFETY INSTRUCTIONS FOR ALL OPERATIONS

### Causes and Operator Prevention of Kickback

*Kickback is a sudden reaction to a pinched or snagged rotating wheel, backing pad, brush or any other accessory. Pinching or snagging causes rapid stalling of the rotating accessory which in turn causes the uncontrolled power tool to be forced in the direction opposite of the accessory's rotation at the point of the binding.*

*For example, if an abrasive wheel is snagged or pinched by the workpiece, the edge of the wheel that is entering into the pinch point can dig into the surface of the material causing the wheel to climb out or kick out. The wheel may either jump toward or away from the operator, depending on direction of the wheel's movement at the point of pinching. Abrasive wheels may also break under these conditions.*

*Kickback is the result of tool misuse and/or incorrect operating procedures or conditions and can be avoided by taking proper precautions as given below:*

- a) **Maintain a firm grip on the power tool and position your body and arm to allow you to resist kickback forces. Always use auxiliary handle, if provided, for maximum control over kickback or torque reaction during start up.** *The operator can control torque reaction or kickback forces, if proper precautions are taken.*
- b) **Never place your hand near the rotating accessory.** *Accessory may kickback over your hand.*
- c) **Do not position your body in the area where power tool will move if kickback occurs.** *Kickback will propel the tool in direction opposite to the wheel's movement at the point of snagging.*
- d) **Use special care when working corners, sharp edges etc. Avoid bouncing and snagging the accessory.** *Corners, sharp edges or bouncing have a tendency to snag the rotating accessory and cause loss of control or kickback.*
- e) **Do not attach a saw chain woodcarving blade or toothed saw blade.** *Such blades create frequent kickback and loss of control.*

### Safety Warnings Specific for Grinding and Abrasive Cutting-Off Operations

- a) **Use only wheel types that are recommended for your power tool and the specific guard designed for the selected wheel.** *Wheels for which the power tool was not designed cannot be adequately guarded and are unsafe.*
- b) **The grinding surface of centre depressed wheels must be mounted below the plane of the guard lip.** *An improperly mounted wheel that projects through the plane of the guard lip cannot be adequately protected.*



- c) **The guard must be securely attached to the power tool and positioned for maximum safety, so the least amount of wheel is exposed towards the operator.**  
The guard helps to protect the operator from broken wheel fragments, accidental contact with wheel and sparks that could ignite clothing.
- d) **Wheels must be used only for recommended applications. For example: do not grind with the side of cut-off wheel.** Abrasive cut-off wheels are intended for peripheral grinding, side forces applied to these wheels may cause them to shatter.
- e) **Always use undamaged wheel flanges that are of correct size and shape for your selected wheel.**  
Proper wheel flanges support the wheel thus reducing the possibility of wheel breakage. Flanges for cut-off wheels may be different from grinding wheel flanges.
- f) **Do not use worn down wheels from larger power tools.** Wheel intended for larger power tool is not suitable for the higher speed of a smaller tool and may burst.

## Additional Safety Warnings Specific for Abrasive Cutting-Off Operations

- a) **Do not "jam" the cut-off wheel or apply excessive pressure. Do not attempt to make an excessive depth of cut.** Overstressing the wheel increases the loading and susceptibility to twisting or binding of the wheel in the cut and the possibility of kickback or wheel breakage.
- b) **Do not position your body in line with and behind the rotating wheel.** When the wheel, at the point of operations, is moving away from your body, the possible kickback may propel the spinning wheel and the power tool directly at you.
- c) **When wheel is binding or when interrupting a cut for any reason, switch off the power tool and hold the power tool motionless until the wheel comes to a complete stop. Never attempt to remove the cut-off wheel from the cut while the wheel is in motion otherwise kickback may occur.** Investigate and take corrective action to eliminate the cause of wheel binding.
- d) **Do not restart the cutting operation in the workpiece. Let the wheel reach full speed and carefully re-enter the cut.** The wheel may bind, walk up or kickback if the power tool is restarted in the workpiece.
- e) **Support panels or any oversized workpiece to minimize the risk of wheel pinching and kickback.**  
Large workpieces tend to sag under their own weight. Supports must be placed under the workpiece near the line of cut and near the edge of the workpiece on both sides of the wheel.
- f) **Use extra caution when making a "pocket cut" into existing walls or other blind areas.** The protruding wheel may cut gas or water pipes, electrical wiring or objects that can cause kickback.

## Safety Warnings Specific for Sanding Operations

- a) **Do not use excessively oversized sanding disc paper. Follow manufacturer's recommendations, when selecting sanding paper.** Larger sanding paper extending beyond the sanding pad presents a laceration hazard and may cause snagging, tearing of the disc or kickback.

## Safety Warnings Specific for Wire Brushing Operations

- a) **Be aware that wire bristles are thrown by the brush even during ordinary operation. Do not overstress the wires by applying excessive load to the brush.**  
The wire bristles can easily penetrate light clothing and/or skin.
- b) **If the use of a guard is recommended for wire brushing, do not allow any interference of the wire wheel or brush with the guard.** Wire wheel or brush may expand in diameter due to work and centrifugal forces.

## Additional Safety Rules for Grinders

- Threaded mounting of accessories must match the grinder spindle thread. For accessories mounted by flanges, the arbor hole of the accessory must fit the locating diameter of the flange. Accessories that do not match the mounting hardware of the power tool will run out of balance, vibrate excessively and may cause loss of control.
- The grinding surface of the centre depressed wheels must be mounted below the plane of the guard lip. An improperly mounted wheel that projects through the plane of the guard lip cannot be adequately protected.



**WARNING:** We recommend the use of a residual current device with a residual current rating of 30mA or less.

## Residual Risks

In spite of the application of the relevant safety regulations and the implementation of safety devices, certain residual risks cannot be avoided. These are:

- Impairment of hearing.
- Risk of personal injury due to flying particles.
- Risk of burns due to accessories becoming hot during operation.
- Risk of personal injury due to prolonged use.
- Risk of dust from hazardous substances.

## Electrical Safety

The electric motor has been designed for one voltage only. Always check that the power supply corresponds to the voltage on the rating plate.



Your DEWALT tool is double insulated in accordance with IEC60745; therefore no earth wire is required.

If the supply cord is damaged, it must be replaced by a specially prepared cord available through the DeWALT service organisation.

## Using an Extension Cable

An extension cord should not be used unless absolutely necessary. Use an approved extension cable suitable for the power input of your charger (see **Technical Data**). The minimum conductor size is 1.5 mm<sup>2</sup>; the maximum length is 30 m.

When using a cable reel, always unwind the cable completely.

## Package Contents

The package contains:

- 1 Angle grinder
- 1 Guard
- 1 Side handle
- 1 Flange set
- 1 Hex key
- 1 Instruction manual
- *Check for damage to the tool, parts or accessories which may have occurred during transport.*
- *Take the time to thoroughly read and understand this manual prior to operation.*

## Markings on Tool

The following pictograms are shown on the tool:



Read instruction manual before use.



Wear ear protection.



Wear eye protection.

## Date Code Position (Fig. C)

The date code **14**, which also includes the year of manufacture, is printed into the housing.

Example:

2016 XX XX

Year of Manufacture

## Description (Fig. A, B)



**WARNING:** Never modify the power tool or any part of it.

*Damage or personal injury could result.*

- 1 Spindle lock button
- 2 Spindle
- 3 Side handle
- 4 Backing flange
- 5 Clamp nut
- 6 Guard
- 7 Trigger switch (Fig.A-1) (DWE8411)  
Slide switch (Fig.A-2) (DWE8410 and DWE8420)
- 8 Lock-off lever

**10** Dust ejection system

**11** Lock on button

## Intended Use

Your heavy-duty small angle grinder has been designed for professional grinding, sanding, wire brushing and cutting applications.

**DO NOT** use grinding wheels other than centre depressed wheels and flap discs.

**DO NOT** use under wet conditions or in the presence of flammable liquids or gases.

Your heavy-duty angle grinder is a professional power tool.

**DO NOT** let children come into contact with the tool.

Supervision is required when inexperienced operators use this tool.

- **Young children and the infirm.** This appliance is not intended for use by young children or infirm persons without supervision.
- This product is not intended for use by persons (including children) suffering from diminished physical, sensory or mental abilities; lack of experience, knowledge or skills unless they are supervised by a person responsible for their safety. Children should never be left alone with this product.

## Dust Ejection System (Fig. A)

The dust ejection system **10** prevents dust pile-up around the guard and motor inlet, and minimises the amount of dust entering the motor housing.

## ASSEMBLY AND ADJUSTMENTS



**WARNING:** To reduce the risk of serious personal injury, turn tool off and disconnect tool from power source before making any adjustments or removing/installing attachments or accessories. Be sure the trigger switch is in the OFF position. An accidental start-up can cause injury.

## Attaching Side Handle (Fig. B)



**WARNING:** Before using the tool, check that the handle is tightened securely.

Screw the side handle **3** tightly into one of the holes on either side of the gear case. The side handle should always be used to maintain control of the tool at all times.

## Mounting Guards



**WARNING:** To reduce the risk of serious personal injury, turn tool off and disconnect tool from power source before making any adjustments or removing/installing attachments or accessories. Before reconnecting the tool, depress and release the trigger switch to ensure that the tool is off.



**CAUTION:** Guards must be used with all grinding wheels, cutting wheels, sanding flap discs, wire brushes, and wire wheels. The tool may be used without a guard only when sanding

with conventional sanding discs. Refer to Figure A to see guards provided with the unit. Some applications may require purchasing the correct guard from your local dealer or authorized service centre.

## Mounting and Removing the Guard (fig. C)



**WARNING:** To reduce the risk of serious personal injury, turn tool off and disconnect tool from power source before making any adjustments or removing/installing attachments or accessories. Before reconnecting the tool, depress and release the trigger switch to ensure that the tool is off.

### MOUNTING CLOSED (TYPE 1) OR STANDARD (TYPE 27) GUARD



**CAUTION:** Turn off and unplug the tool before making any adjustments or removing or installing attachments or accessories. Before reconnecting the tool, turn the switch on and off to ensure that the tool is off.

Hubbed wheels install directly on the M14 spindle. Thread of accessory must match thread of spindle.

1. Loosen screw, until the guard lug (13) can rotate freely in the groove (12) on the gear case hub.
2. Rotate guard (6) into desired working position. The guard body should be positioned between the spindle and the operator to provide maximum operator protection.
3. Tighten the screw (9) to secure the guard on the gear case cover. (Fasten torque no less than 2.5 N-M). You should be unable to rotate the guard by hand. Do not operate grinder with a loose guard.
4. To remove the guard, loosen screw and pull up on the guard.

### TO REMOVE THE GUARD

1. Loosen the screw holding the cinch collar around the neck of the spindle.
2. Lift up on the guard.
1. **WARNING:** Never use the tool without the guard in place.

## Flanges and Wheels

### Mounting Non-Hubbed Wheels (Fig. D-1)



**WARNING:** Failure to properly seat the flange/ clamp nut/ wheel could result in serious injury (or damage to the tool or wheel).



**CAUTION:** Included flanges must be used with depressed centre Type 27 and Type 42 grinding wheels and Type 41 cutting wheels. See the **Accessories Chart** for more information.



**WARNING:** A closed, two-sided cutting wheel guard is required when using cutting wheels.



**WARNING:** Use of a damaged flange or guard or failure to use proper flange and guard can result in injury due to wheel breakage and wheel contact. See the **Accessories Chart** for more information.

1. Place the tool on a table, guard up.
2. Install the unthreaded backing flange **4** on spindle **2** with the raised centre (pilot) facing the wheel.
3. Place wheel **16** against the backing flange, centring the wheel on the raised centre (pilot) of the backing flange.
4. While depressing the spindle lock button and with the hex depressions facing away from the wheel, thread the clamp nut **5** on spindle so that the lugs engage the two slots in the spindle.
5. While depressing the spindle lock button, tighten the locking flange with a wrench **20**.
6. To remove the wheel, depress the spindle lock button and loosen the threaded locking flange with a wrench.

### Mounting Sanding Backing Pads (Fig. D-2)

**NOTE:** Use of a guard with sanding discs that use backing pads, often called fiber resin discs, is not required. Since a guard is not required for these accessories, the guard may or may not fit correctly if used.



**WARNING:** Failure to properly seat the flange/ clamp nut/ wheel could result in serious injury (or damage to the tool or wheel).



**WARNING:** Proper guard must be reinstalled for grinding wheel, cutting wheel, sanding flap disc, wire brush or wire wheel applications after sanding applications are complete.

1. Place or appropriately thread backing pad **17** on the spindle.
2. Place the sanding disc **18** on the backing pad **17**.
3. While depressing spindle lock **1**, thread clamp nut **19** on spindle, piloting the raised hub on the clamp nut into the centre of sanding disc and backing pad.
4. Tighten the clamp nut by hand. Then depress the spindle lock button while turning the sanding disc until the sanding disc and clamp nut are snug.
5. To remove the wheel, grasp and turn the backing pad and sanding pad while depressing the spindle lock button.

## Mounting and Removing Hubbed Wheels

Hubbed wheels install directly on the M14 threaded spindle. Thread of accessory must match thread of spindle.

1. Remove backing flange by pulling away from tool.
2. Thread the wheel on the spindle ② by hand.
3. Depress the spindle lock button ① and use a wrench to tighten the hub of the wheel.
4. Reverse the above procedure to remove the wheel.

**NOTICE:** Failure to properly seat the wheel before turning the tool on may result in damage to the tool or the wheel.

## Mounting Wire Cup Brushes and Wire Wheels

**WARNING:** Failure to properly seat the flange/ clamp nut/ wheel could result in serious injury (or damage to the tool or wheel).

**CAUTION:** To reduce the risk of personal injury, wear work gloves when handling wire brushes and wheels. They can become sharp.

**CAUTION:** To reduce the risk of damage to the tool, wheel or brush must not touch guard when mounted or while in use. Undetectable damage could occur to the accessory, causing wires to fragment from accessory wheel or cup.

Wire cup brushes or wire wheels install directly on the threaded spindle without the use of flanges. Use only wire brushes or wheels provided with a M14 threaded hub. These accessories are available at extra cost from your local dealer or authorised service centre.

1. Place the tool on a table, guard up.
2. Thread the wheel on the spindle by hand.
3. Depress spindle lock button ① and use a wrench on the hub of the wire wheel or brush to tighten the wheel.
4. To remove the wheel, reverse the above procedure.

**NOTICE:** To reduce the risk of damage to the tool, properly seat the wheel hub before turning the tool on.

## Prior to Operation

- Install the guard and appropriate disc or wheel. Do not use excessively worn discs or wheels.
- Be sure the inner and outer flange are mounted correctly. Follow the instructions given in the **Grinding and Cutting Accessory Chart**.
- Make sure the disc or wheel rotates in the direction of the arrows on the accessory and the tool.
- Do not use a damaged accessory. Before each use inspect the accessory such as abrasive wheels for chips and cracks, backing pad for cracks, tear or excess wear, wire brush for loose or cracked wires. If power tool or accessory is dropped, inspect for damage or install an undamaged accessory. After inspecting and installing an accessory, position yourself and bystanders away from the plane of the rotating accessory and run the power tool at maximum no-load speed for one minute. Damaged accessories will normally break apart during this test time.

## OPERATION

### Instructions for Use

- WARNING:** Always observe the safety instructions and applicable regulations.
- WARNING:** To reduce the risk of serious personal injury, turn tool off and disconnect tool from power source before making any adjustments or removing/installing attachments or accessories. Be sure the trigger switch is in the OFF position. An accidental start-up can cause injury.
- WARNING:**
  - Ensure all materials to be ground or cut are secured in place.
  - Secure and support the workpiece. Use clamps or a vice to hold and support the workpiece to a stable platform. It is important to clamp and support the workpiece securely to prevent movement of the workpiece and loss of control. Movement of the workpiece or loss of control may create a hazard and cause personal injury.
  - Support panels or any oversized workpiece to minimize the risk of wheel pinching and kickback. Large workpieces tend to sag under their own weight. Supports must be placed under the workpiece near the line of cut and near the edge of the workpiece on both sides of the wheel.
  - Always wear regular working gloves while operating this tool.
  - The gear becomes very hot during use.
  - Apply only a gentle pressure to the tool. Do not exert side pressure on the disc.
  - Always install the guard and appropriate disc or wheel. Do not use excessively worn disc or wheel.
  - Be sure the inner and outer flange are mounted correctly.
  - Make sure the disc or wheel rotates in the direction of the arrows on the accessory and the tool.
  - Avoid overloading. Should the tool become hot, let it run a few minutes under no load condition to cool the accessory. Do not touch accessories before they have cooled. The discs become very hot during use.
  - Never work with the grinding cup without a suitable protection guard in place.
  - Do not use the power tool with a cut-off stand.
  - Never use blotters together with bonded abrasive products.
  - Be aware, the wheel continues to rotate after the tools is switched off.

### Proper Hand Position (Fig. G)

- WARNING:** To reduce the risk of serious personal injury, ALWAYS use proper hand position as shown.

**WARNING:** To reduce the risk of serious personal injury, **ALWAYS** hold securely in anticipation of a sudden reaction.

Proper hand position requires one hand on the side handle **3**, with the other hand on the body of the tool, as shown in Figure G.

## Trigger Switch (Fig. A-1)

**CAUTION:** Hold the side handle and body of the tool firmly to maintain control of the tool at start up and during use and until the wheel or accessory stops rotating. Make sure the wheel has come to a complete stop before laying the tool down.

**NOTE:** To reduce unexpected tool movement, do not switch the tool on or off while under load conditions. Allow the grinder to run up to full speed before touching the work surface. Lift the tool from the surface before turning the tool off. Allow the tool to stop rotating before putting it down.

1. To turn the tool on, push the lock-off lever **8** toward the back of the tool, then depress the trigger switch **7**. The tool will run while the switch is depressed.
2. Turn the tool off by releasing the trigger switch.

## Lock-On Button (DWE8411 Only)

The lock-on button **11** offers increased comfort in extended use applications. To lock the tool on, depress the lock-on button when the tool is running. The tool will continue to run after the paddle switch is released. To unlock the tool, depress and release the paddle switch. This will cause the tool to stop.

## Slider Switch (Fig. A-2) (DWE8410 and DWE8420)

**CAUTION:** Hold the side handle and body of the tool firmly to maintain control of the tool at start up and during use and until the wheel or accessory stops rotating. Make sure the wheel has come to a complete stop before laying the tool down.

**NOTE:** To reduce unexpected tool movement, do not switch the tool on or off while under load conditions. Allow the grinder to run up to full speed before touching the work surface. Lift the tool from the surface before turning the tool off. Allow the tool to stop rotating before putting it down.

**WARNING:** Before connecting the tool to a power supply, be sure the slider switch is in the off position by pressing the rear part of the switch and releasing. Ensure the slider switch is in the off position as described above after any interruption in power supply to the tool, such as the activation of a ground fault interrupter, throwing of a circuit breaker, accidental unplugging, or power failure. If the slider switch is locked on when the power is connected, the tool will start unexpectedly.

To start the tool, slide the ON/OFF slider switch **7** toward the front of the tool. To stop the tool, release the ON/OFF slider switch.

For continuous operation, slide the switch toward the front of the tool and press the forward part of the switch inward. To stop the tool while operating in continuous mode, press the rear part of the slider switch and release.

## Spindle Lock (Fig. B)

The spindle lock **1** is provided to prevent the spindle from rotating when installing or removing wheels. Operate the spindle lock only when the tool is turned off, unplugged from the power supply, and has come to a complete stop.

**NOTICE:** To reduce the risk of damage to the tool, do not engage the spindle lock while the tool is operating. Damage to the tool will result and attached accessory may spin off possibly resulting in injury.

To engage the lock, depress the spindle lock button and rotate the spindle until you are unable to rotate the spindle further.

## Surface Grinding, Sanding and Wire Brushing

**CAUTION:** Always use the correct guard per the instructions in this manual.

**WARNING: Metal dust build-up.** Extensive use of flap discs in metal applications can result in the increased potential for electric shock. To reduce this risk, insert an RCD before use and clean the ventilation slots daily by blowing dry compressed air into the ventilation slots in accordance with the below maintenance instructions.

To perform work on a the surface of a workpiece:

1. Allow the tool to reach full speed before touching the tool to the work surface.
2. Apply minimum pressure to the work surface, allowing the tool to operate at high speed. Material removal rate is greatest when the tool operates at high speed.

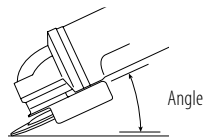

3. Maintain an appropriate angle between the tool and work surface. Refer to the chart according to particular function.

Function	Angle
Grinding	20°-30°
Sanding with Flap Disc	5°-10°
Sanding with Backing Pad	5°-15°
Wire Brushing	5°-10°

4. Maintain contact between the edge of the wheel and the work surface.
  - If grinding, sanding with flap discs or wire brushing move the tool continuously in a forward and back motion to avoid creating gouges in the work surface.
  - If sanding with a backing pad, move the tool constantly in a straight line to prevent burning and swirling of work surface.

**NOTE:** Allowing the tool to rest on the work surface without moving will damage the work piece.

- Remove the tool from work surface before turning tool off. Allow the tool to stop rotating before laying it down.



**CAUTION:** Use extra care when working over an edge, as a sudden sharp movement of grinder may be experienced.

## Precautions To Take When Working on a Painted Workpiece

- Sanding or wire brushing of lead based paint is NOT RECOMMENDED due to the difficulty of controlling the contaminated dust. The greatest danger of lead poisoning is to children and pregnant women.
- Since it is difficult to identify whether or not a paint contains lead without a chemical analysis, we recommend the following precautions when sanding any paint:

### Personal Safety

- No children or pregnant women should enter the work area where the paint sanding or wire brushing is being done until all clean up is completed.
- A dust mask or respirator should be worn by all persons entering the work area. The filter should be replaced daily or whenever the wearer has difficulty breathing.
 

**NOTE:** Only those dust masks suitable for working with lead paint dust and fumes should be used. Ordinary painting masks do not offer this protection. See your local hardware dealer for the proper N.I.O.S.H. approved mask.
- NO EATING, DRINKING or SMOKING should be done in the work area to prevent ingesting contaminated paint particles. Workers should wash and clean up BEFORE eating, drinking or smoking. Articles of food, drink, or smoking should not be left in the work area where dust would settle on them.

### Environmental Safety

- Paint should be removed in such a manner as to minimize the amount of dust generated.
- Areas where paint removal is occurring should be sealed with plastic sheeting of 4 mils thickness.
- Sanding should be done in a manner to reduce tracking of paint dust outside the work area.

### Cleaning and Disposal

- All surfaces in the work area should be vacuumed and thoroughly cleaned daily for the duration of the sanding project. Vacuum filter bags should be changed frequently.
- Plastic drop cloths should be gathered up and disposed of along with any dust chips or other removal debris. They should be placed in sealed refuse receptacles and disposed of through regular trash pick-up procedures. During clean up, children and pregnant women should be kept away from the immediate work area.
- All toys, washable furniture and utensils used by children should be washed thoroughly before being used again.

## Edge Grinding and Cutting



**WARNING:** Do not use edge grinding/cutting wheels for surface grinding applications because these wheels are not designed for side pressures encountered with surface grinding. Wheel breakage and injury may result.



**CAUTION:** Wheels used for edge grinding and cutting may break or kick back if they bend or twist while the tool is being used. In all edge grinding/cutting operations, the open side of the guard must be positioned away from the operator.

**NOTICE:** Edge grinding/cutting with a Type 27 wheel must be limited to shallow cutting and notching—less than 13 mm in depth when the wheel is new. Reduce the depth of cutting/notching equal to the reduction of the wheel radius as it wears down. Refer to the **Accessories Chart** for more information. Edge grinding/cutting with a Type 41 wheel requires usage of a Type 1 guard.

- Allow the tool to reach full speed before touching the tool to the work surface.
- Apply minimum pressure to the work surface, allowing the tool to operate at high speed. Grinding/cutting rate is greatest when the tool operates at high speed.
- Position yourself so that the open-underside of the wheel is facing away from you.
- Once a cut is begun and a notch is established in the workpiece, do not change the angle of the cut. Changing the angle will cause the wheel to bend and may cause wheel breakage. Edge grinding wheels are not designed to withstand side pressures caused by bending.
- Remove the tool from the work surface before turning the tool off. Allow the tool to stop rotating before laying it down.

## Metal Applications

When using the tool in metal applications, make sure that a residual current device (RCD) has been inserted to avoid residual risks caused by metal swarf.

If the power supply is shut off by the RCD, take the tool to an authorised DEWALT repair agent.



**WARNING:** In extreme working conditions, conductive dust can accumulate inside the machine housing when working with metal. This can result in the protective insulation in the machine becoming degraded with a potential risk of an electrical shock.

To avoid build-up of metal swarf inside the machine, we recommend to clear the ventilation slots on a daily basis. Refer to **Maintenance**.

## Cutting Metal

**For cutting with bonded abrasives, always use the guard type 1.**

When cutting, work with moderate feed, adapted to the material being cut. Do not exert pressure onto the cutting disc, tilt or oscillate the machine.

Do not reduce the speed of running down cutting discs by applying sideward pressure.

The machine must always work in an upgrinding motion. Otherwise, the danger exists of it being pushed uncontrolled out of the cut.

When cutting profiles and square bar, it is best to start at the smallest cross section.

## Rough Grinding

**Never use a cutting disc for roughing.**  
**Always use the guard type 27.**

The best roughing results are achieved when setting the machine at an angle of 30° to 40°. Move the machine back and forth with moderate pressure. In this manner, the workpiece will not become too hot, does not discolour and no grooves are formed.

## Cutting Stone

**The machine shall be used only for dry cutting.**

For cutting stone, it is best to use a diamond cutting disc. Operate the machine only with additional dust protection mask.

## Working Advice

**Exercise caution when cutting slots in structural walls.**

Slots in structural walls are subject to the country-specific regulations. These regulations are to be observed under all circumstances. Before beginning work, consult the responsible structural engineer, architect or the construction supervisor.

## MAINTENANCE

Your DEWALT power tool has been designed to operate over a long period of time with a minimum of maintenance. Continuous satisfactory operation depends upon proper tool care and regular cleaning.

 **WARNING:** To reduce the risk of serious personal injury, turn tool off and disconnect tool from power source before making any adjustments or removing/installing attachments or accessories. Be sure the trigger switch is in the OFF position. An accidental start-up can cause injury.

## Pop-off Brushes

The motor will be automatically shut off indicating that the carbon brushes are nearly worn out and that the tool needs servicing. The carbon brushes are not user-serviceable. Take the tool to an authorised DEWALT repair agent.



## Lubrication

Your power tool requires no additional lubrication.



## Cleaning

 **WARNING:** Blow dirt and dust out of the main housing with dry air as often as dirt is seen collecting in and around

the air vents. Wear approved eye protection and approved dust mask when performing this procedure.



**WARNING:** Never use solvents or other harsh chemicals for cleaning the non-metallic parts of the tool. These chemicals may weaken the materials used in these parts. Use a cloth dampened only with water and mild soap. Never let any liquid get inside the tool; never immerse any part of the tool into a liquid.

## Optional Accessories



**WARNING:** Since accessories, other than those offered by DEWALT, have not been tested with this product, use of such accessories with this tool could be hazardous. To reduce the risk of injury, only DEWALT recommended accessories should be used with this product.

Consult your dealer for further information on the appropriate accessories.

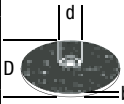
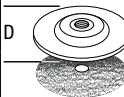
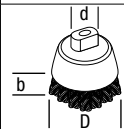
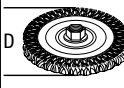
	Max. [mm]		[mm]	Min. Rotation [min. <sup>-1</sup> ]	Peripheral speed [m/s]	Threaded hole length [mm]
	D	b	d			
	115	6	22,23	11,500	80	–
	125	6	22,23	11,500	80	–
	150	6	22,23	9,500	80	–
	115	–	–	11,500	80	–
	125	–	–	11,500	80	–
	75	30	M14	11,500	45	20.0
	115	12	M14	11,500	80	20.0
	125	12	M14	11,500	80	20.0

## Protecting the Environment



Separate collection. Products and batteries marked with this symbol must not be disposed of with normal household waste.



Products and batteries contain materials that can be recovered or recycled reducing the demand for raw materials. Please recycle electrical products and batteries according to local provisions. Further information is available at [www.2helpU.com](http://www.2helpU.com).

# 角磨机

## DWE8410、DWE8420、DWE8411、DWE8421

### 恭喜！

感谢您选购 DEWALT 工具。凭借多年的产品开发和创新能力，DEWALT 已经成为专业电动工具用户最可靠的合作伙伴之一。

### 技术参数

		DWE8410	DWE8420	DWE8411	DWE8421
电压	V <sub>AC</sub>	220V	220V	220V	220V
输入功率	瓦	1400	1400	1400	1400
额定速度	转/分钟	10500	9500	10500	9500
砂轮直径	毫米	125	150	125	150
砂轮厚度（最大）	毫米	6.0	6.0	6.0	6.0
主轴直径		M14	M14	M14	M14
主轴长度	毫米	18.5	18.5	18.5	18.5
重量	千克	2.5*	2.5*	2.5*	2.5*

\*重量包括侧手柄和防护罩

### 定义：安全指南

下列定义描述了各标志术语的严重程度。请仔细阅读本手册，并注意这些标志。



**危险：**表示存在紧急危险情况，如果不加以避免，将导致死亡或严重伤害。



**警告：**表示存在潜在的危险情况，如果不加以避免，可能导致死亡或严重伤害。



**警示：**表示存在潜在危险情况，如果不加以避免，可能导致轻度或中度伤害。

**注意：**表示存在不涉及人身伤害的情况，如果不加以避免，可能导致财产损失。



表示存在触电风险。



表示存在火灾风险。

### 电动工具通用安全警告



**警告！**请仔细阅读所有安全警告和说明。如不遵守以下任何警告和说明，可能会导致触电、火灾和/或严重伤害。

请妥善保存所有警告和说明，以备将来查阅。

下列所有警告中的“电动工具”一词是指电源驱动（有线）电动工具，或者电池驱动（无线）电动工具。

#### a) 工作场地的安全

- 1) **保持工作场地清洁和明亮。**混乱和黑暗的场地会引发事故。
- 2) **不要在易爆环境，如有易燃液体、气体或粉尘的环境下操作电动工具。**电动工具产生的火花会点燃粉尘或气体。
- 3) **让儿童和旁观者离开后操作电动工具。**注意力不集中会使你失去对工具的控制。

#### b) 电气安全

- 1) **电动工具插头必须与插座相配。绝不能以任何方式改装插头。**需接地的电动工具不能使用任何转换插头。未经改装的插头和相配的插座将减少电击危险。
- 2) **避免人体接触接地表面，如管道、散热片和冰箱。**如果你身体接地会增加电击危险。



- 3) **不得将电动工具暴露在雨中或潮湿环境中。**水进入电动工具将增加电击危险。
- 4) **不得滥用电线。绝不能用电线搬运、拉动电动工具或拔出其插头。**使电线远离热源、油、锐边或运动部件。受损或缠绕的软线会增加电击危险。
- 5) **当在户外使用电动工具时，使用适合户外使用的外接软线。**适合户外使用的软线将减少电击危险。
- 6) **如果在潮湿环境下操作电动工具是不可避免的，应使用剩余电流动作保护器（RCD）。**使用RCD可减小电击危险。
- c) **人身安全**
  - 1) **保持警觉，当操作电动工具时关注所从事的操作并保持清醒。**当你感到疲倦，或在有药物、酒精或治疗反应时，不要操作电动工具。在操作电动工具时瞬间的疏忽会导致严重人身伤害。
  - 2) **使用个人防护装置。始终佩戴护目镜。**安全装置，诸如适当条件下使用防尘面具、防滑安全鞋、安全帽、听力防护等装置能减少人身伤害。
  - 3) **防止意外起动。确保开关在连接电源和/或电池组、拿起或搬运工具时处于关断位置。**手指放在已接通电源的开关上或开关处于接通时插入插头可能会导致危险。
  - 4) **在电动工具接通之前，拿掉所有调节钥匙或扳手。**遗留在电动工具旋转零件上的扳手或钥匙会导致人身伤害。
  - 5) **手不要伸展得太长。时刻注意立足点和身体平衡。**这样在意外情况下能很好地控制电动工具。
  - 6) **着装适当。不要穿宽松衣服或佩戴饰品。让你的衣服、手套和头发远离运动部件。**宽松衣服、配饰或长发可能会卷入运动部件中。
  - 7) **如果提供了与排屑、集尘设备连接用的装置，要确保他们连接完好且使用得当。**使用这些装置可减少尘屑引起的危险。
- d) **电动工具使用和注意事项**
  - 1) **不要滥用电动工具，根据用途使用适当的电动工具。**选用适当设计的电动工具会使你工作更有效、更安全。
  - 2) **如果开关不能接通或关断工具电源，则不能使用该电动工具。**不能用开关来控制的电动工具是危险的且必须进行修理。
  - 3) **在进行任何调节、更换附件或贮存电动工具之前，必须从电源上拔掉插头和/或使电池组与工具脱开。**这种防护性措施将减少工具意外起动的危险。
  - 4) **将闲置不用的电动工具贮存在儿童所及范围之外，并且不要让不熟悉电动工具或对这些说明不了解的人操作电动工具。**电动工具在未经培训的用户手中是危险的。
  - 5) **保养电动工具。检查运动件是否调整到位或卡住，检查零件破损情况和影响电动工具运行的其他状况。**如有损坏，电动工具应在使用前修理好。许多事故由维护不良的电动工具引发。
  - 6) **保持切削刀具锋利和清洁。**保养良好的有锋利切削刃的刀具不易卡住而且容易控制。
  - 7) **按照使用说明书，考虑作业条件和进行的作业来使用电动工具、附件和工具的刀头等。**将电动工具用于那些与其用途不符的操作可能会导致危险。
- e) **维修**

**将你的电动工具送交专业维修人员，使用同样的备件进行修理。**这样将确保所维修的电动工具的安全性。

## 附加安全细则

### 砂磨、切割操作的通用安全警告：

- a) **该电动工具是实现砂轮机、切断工具功能的，阅读随该电动工具提供的所有安全警告、说明、图解和规定。**不了解以下所列所有说明将导致电击、着火和/或严重伤害。

- b) **不推荐用该电动工具进行诸如砂光、刷光、抛光等操作。**电动工具不按指定的功能去操作，可能会发生危险和引起人身伤害。
- c) **不使用非工具制造商推荐和专门设计的附件。**否则该附件可能被装到你的电动工具上，而它不能保证安全操作。
- d) **附件的额定速度必须至少等于电动工具上标出的最大速度。**附件以比其额定速度大的速度运转会发生爆裂和飞溅。
- e) **附件的外径和厚度必须在电动工具额定能力范围之内。**不正确的附件尺寸不能得到充分防护或控制。
- f) **砂轮、法兰盘、靠背垫或任何其他附件的轴孔尺寸必须适合于安装到电动工具的主轴上。**带轴孔的、与电动工具安装件不配的附件将会失稳、过度振动并会引起失控。
- g) **不要使用损坏的附件。在每次使用前要检查附件，例如砂轮是否有碎片和裂缝，靠背垫是否有的裂缝、撕裂或过度磨损，钢丝刷是否松动或金属丝是否断裂。如果电动工具或附件跌落，检查是否有损坏或安装没有损坏的附件。检查和安装附件后，让自己和旁观者的位置远离旋转附件的平面，并以电动工具最大空载速度运行1分钟。损坏的附件通常在该试验时会碎裂。**
- h) **戴上防护用品。根据适用情况，使用面罩、安全护目镜或安全眼镜。适用时，戴上防尘面具、听力保护器、手套和能挡小磨料或工件碎片的工场围裙。**眼防护罩必须挡住各种操作产生的飞屑。防护面具或口罩必须能过滤操作产生的颗粒。长期暴露在高强度噪声中会引起失聪。
- i) **让旁观者与工作区域保持一安全距离。任何进入工作区域的人必须戴上防护用品。工件或破损附件的碎片可能会飞出并引起紧靠着操作区域后面的旁观者的伤害。**切割附件触及带电导线会使电动工具外露的金属零件带电，并使操作者触电。
- j) **当在切割附件有可能切割到暗线或自身电线的场所进行操作时，只能通过绝缘握持面来握住电动工具。**切割附件碰到一根带电导线可能会使电动工具的外露金属零件带电并使操作者发生电击危险。
- k) **使软线远离旋转的附件。**如果控制不当，软线可能被切断或缠绕，并使得你的手或手臂可能被卷入旋转附件中
- l) **直到附件完全停止运动才放下电动工具。**旋转的附件可能会抓住表面并拉开电动工具而让你失去对工具的控制。
- m) **当携带电动工具时不要开动它。**意外地触及旋转附件可能会缠绕你的衣服而使附件伤害身体。
- n) **经常清理电动工具的通风口。**电动机风扇会将灰尘吸进机壳，过多的金属粉末沉淀会导致电气危险。
- o) **不要在易燃材料附近操作电动工具。**火星可能会点燃这些材料。
- p) **不要使用需用冷却液的附件。**用水或其他冷却液可能会导致电腐蚀或电击。

## 对所有操作的进一步安全说明 反弹和相关警告：

反弹是因卡住或缠绕住的旋转砂轮、靠背垫、钢丝刷或其他附件而产生的突然反作用力。卡住或缠绕会引起旋转附件的迅速堵转，随之使失控的电动工具在卡住点与附件旋转方向相反的运动。

例如。如果砂轮被工件缠绕或卡住，伸入卡住点的砂轮边缘可能会进入材料表面而引起砂轮爬出或反弹。砂轮可能飞向或飞离操作者，这取决于砂轮在卡住点的运动方向。在此条件下砂轮也可能碎裂。

反弹是电动工具误用和/或不正确操作工序或条件的结果，可以通过采取以下给出的适当预防措施得以避免。

- a) **保持紧握电动工具，使你的身体和手臂处于正确状态以抵抗反弹力。如有辅助手柄，则要一直使用。以便最大限度控制启动时的反弹力或反力**

矩。如采取合适的预防措施，操作者就可以控制反力矩或反弹力。

- b) **绝不能将手靠近旋转附件。**附件可能会反弹碰到手。
- c) **不要站在发生反弹时电动工具将要移动到的地方。**反弹将在缠绕点驱使工具逆砂轮运动方向运动。
- d) **当在尖角、锐边等处作业时要特别小心。避免附件的弹跳和缠绕。**尖角、锐边和弹跳具有缠绕旋转附件的趋势并引起反弹的失控。
- e) **不要附上锯链、木雕刀片或带齿锯片。**这些锯片会产生频繁的反弹和失控。

## 砂轮和切割操作的附加安全说明

### 对磨削和砂磨切割操作的专用安全警告：

- a) **只使用推荐给电动工具的砂轮型号和为选用砂轮专用设计的护罩。**不是为电动工具设计的砂轮不能充分得到防护，是不安全的。
- b) **护罩必须牢固地装在电动工具上，且放置得最具安全性，只有最小的砂轮部分暴露在操作人面前。**护罩帮助保护操作者免于爆裂砂轮的碎片的危害和偶然触及砂轮的危险。
- c) **砂轮只用作推荐的用途。例如：不要用切割砂轮的侧面进行磨削。**施加到砂轮侧面的力可能会使其碎裂。
- d) **始终为所选砂轮选用未损坏的、有恰当规格和形状的砂轮压板法兰盘。**合适的砂轮法兰盘支撑砂轮可以减小砂轮破裂的可能性。切割砂轮的法兰盘可以不同于砂轮法兰盘。
- e) **不要使用从大规模电动工具上用剩的磨损砂轮。**用于大规模电动工具上的砂轮不适用于较小规格工具的高速工况并可能会爆裂。

### 对砂轮切割操作的附加专用安全警告：

- a) **不要“夹”住切割砂轮或施加过大的压力。不要试图做过深的切割。**给砂轮施加过应力增加

了砂轮在切割时的负载，容易缠绕或卡住，增加了反弹或砂轮爆裂的可能性。

- b) **身体不要对着旋转砂轮，也不要站在其后。**当把砂轮从操作者身边的操作点移开时，可能的反弹会使旋转砂轮和电动工具朝你推来。
- c) **当砂轮被卡住或无论任何原因而中断切割时，关掉电动工具并握住工具不要动，直到砂轮完全停止。决不要试图当砂轮仍然运转时使切割砂轮脱离切割，否则会发生反弹。**调查并采取校正措施以消除砂轮卡住的原因。
- d) **不能在工件上重新启动切割操作。让砂轮达到全速后再小心地重新进入切割。**如果电动工具在工件上重新启动，砂轮可能会卡住、爬出或反弹。
- e) **支撑住板材或超大工件可使得砂轮卡住和反弹的危险降到最低限度。**大工件凭借自重而下垂。必须在工件靠近切割线处和砂轮两侧近工件边缘处放置支撑。
- f) **当进行“盲切割”进入墙体或其它盲区时要格外小心。**伸出的砂轮可能会割到煤气管或水管，电线或由此引起反弹的物体。

## 角磨机的附加安全细则

- 附件的螺纹安装必须与砂轮机主轴螺纹相配。对于通过法兰安装的附件，附件的轴孔必须适合法兰的定位直径。与电动工具安装件不相配的附件将失衡、过度震动并会引起失控。
- 中心凹陷的砂轮的磨削表面必须安装在防护罩边缘平面的下方。安装不当且穿过防护罩边缘平面的砂轮得不到充分保护。

 **警告：**我们建议使用漏电保护额定电流为 30 毫安或以下的漏电保护装置。

## 其他风险

尽管遵守了相关的安全法规并采用了安全装备，某些其他风险仍然是无法避免的。这些风险包括：

- 听力损伤。
- 飞溅颗粒造成的人身伤害风险。
- 使用时附件发热导致的灼伤风险。

- 长时间使用引起的人身伤害风险。
- 危害物质粉尘引起的风险。

## 电气安全

电机只适用一种工作电压。请务必检查电源电压是否与铭牌上的电压一致。



您的 DeWALT 工具依据 IEC60745 标准设置双重绝缘，因此无须接地线。

若电源线损坏，必须交由 DeWALT 维修部门采用专门制备的电线进行更换。

### 使用延长线

除非绝对必要，否则请勿使用延长线。使用适合您的充电器输入功率的合格延长线（见**技术参数**）。最小的导线尺寸为 1.5 平方毫米；最大长度为 30 米。

使用电缆卷筒时，请务必拉出所有的电缆。

## 包装内的物品

包装内的物品包括：

- 1 个角磨机
  - 1 个防护罩
  - 1 个侧手柄
  - 1 个法兰套件
  - 1 个六角扳手
  - 1 本说明手册
- 检查工具、部件或附件是否在运输过程中损坏。
  - 操作前，请抽空仔细阅读并掌握本手册。

## 工具上的标记

工具上印有下列图形：



使用前请阅读使用手册。



请佩戴护目装备。

### 日期码位置 (图 C)

日期码 **14** 印在工具外壳上，其中还包含制造年份。

示例：

2016 XX XX

制造年份

## 说明 (图 A、B)



**警告：**切勿改装电动工具或其任何部件，否则可能会导致损坏或人身伤害。

- 1 主轴锁按钮
- 2 主轴
- 3 侧手柄
- 4 靠背法兰
- 5 螺钉锁定法兰
- 6 防护罩
- 7 扳机开关 (图 A-1) (DWE8411 和 DWE8421)  
滑动开关 (图 A-2) (DWE8420 和 DWE8410)
- 8 锁止杆
- 10 排尘系统
- 11 开关锁钮

### 设计用途

您的重型角磨机设计用于专业磨削和切割。

**请勿**使用中心凹陷砂轮以外的砂轮和砂轮机片。

**请勿**在潮湿环境中或在有易燃液体或气体的环境中使用。

您的重型角磨机是专业型电动工具。

**请勿**让儿童接触本工具。缺乏经验的操作员需要在监督下使用本工具。

- **儿童和体弱者。**在没有他人监督的情况下，儿童或体弱者不适宜使用本产品。
- 本产品不适合体力、感官或智力不足以及缺乏经验、知识或技能的人员（包括儿童）使用，除非一旁有能为他们的安全负责的监督人员。不得在无人监管的情况下让儿童接触本产品。

## 排尘系统 (图 A)

排尘系统 **10** 防止灰尘在防护罩和电机入口积聚，最大程度减少进入电机壳的积尘量。

## 组装与调整



**警告：**为降低严重的人身伤害风险，在进行任何调整或取出/安装附件或配件之前，请关闭工具电源和断开工具电源连接。请确保触发开关处于 OFF (关闭) 位置。意外启动可能会导致人身伤害。

## 安装侧手柄（图 B）

 **警告：** 使用工具之前，请检查手柄是否牢固拧紧。

将侧手柄 **3** 牢固地旋入齿轮箱任一侧的其中一个孔中。应始终使用侧手柄，以时刻保持对工具的控制。

## 安装和拆卸防护罩（图 C）

 **警告：** 为降低严重的人身伤害风险，在进行任何调整或移除/安装配件或附件之前，请关闭工具电源和断开工具电源连接。重新连接工具之前，请按下并松开触发开关以确保工具已关闭。

 **警告：** 所有砂轮、切割轮必须使用防护罩。请参阅图 A，了解装置提供的防护罩。某些应用可能需要从本地经销商或经过授权的服务中心购买适当的防护罩。

### 安装封闭式（1 型号）或标准（27 型号）防护罩

 **警告：** 关闭工具的电源并拔下插头，然后调整、拆除或安装配件或附件。重新连接工具之前，请打开开关，然后将其关闭以确保工具已关闭。

带轮毂的砂轮直接安装到 M14 主轴上。附件的螺纹必须与主轴的螺纹相配。

1. 旋松螺丝，直到防护罩凸耳 (13) 可以在齿轮箱轮毂上的凹槽 (12) 中自由转动。
2. 将防护罩 (6) 旋转入所需的工作位置。防护罩主体应位于主轴与操作人员之间，为操作人员提供最大保护。
3. 拧紧螺丝 (9)，将防护罩固定在齿轮箱盖上。（紧固扭矩不小于 2.5 牛米）。切勿用手转动防护罩。切勿操作防护罩松动的角磨机。
4. 若要移除防护罩，请旋松螺丝并将其从防护罩中拔出。

### 拆除防护罩

1. 松开围绕主轴颈部固定夹紧环的螺钉。
2. 将防护罩往上拉。

 **警告：** 切勿在没有安装防护罩的情况下使用本工具。

## 法兰和砂轮

### 安装不带轮毂的砂轮（图 D-1）

 **警告：** 未能正确放置法兰/紧固螺母/砂轮可能会导致严重人身伤害（或者损坏工件或砂轮）。

 **警告：** 随附的法兰必须与 27 型号和 42 型号中心凹陷的砂轮以及 41 型号切割轮搭配使用。有关详细信息，请参阅附件图表。

 **警告：** 使用切割轮时，需要闭合的双面切割轮防护罩。

 **警告：** 使用受损的法兰或防护罩，或者未使用适当的法兰或防护罩可能会由于砂轮破损或砂轮接触而导致人身伤害。有关详细信息，请参阅附件图表。

1. 将工具放置在工作台上，防护罩朝上。
2. 让凸起的中心（导杆）面向砂轮，将非螺纹靠背法兰 **4** 安装到主轴 **2** 上。
3. 将砂轮 **16** 紧靠靠背法兰，让砂轮在靠背法兰凸起中心（导杆）置中。
4. 按下主轴锁按钮并使六角凹陷背向砂轮，将螺纹锁定法兰 **5** 拧上主轴，使接片与主轴上的两个插槽啮合。
5. 在按下主轴锁按钮时，使用扳手 **20** 拧紧紧固螺母。
6. 要拆下砂轮，按下主轴锁按钮并使用扳手拧松螺纹锁定法兰。

### 安装和拆下带轮毂的砂轮

带轮毂的砂轮直接安装到 M14 螺纹主轴上。附件的螺纹必须与主轴的螺纹相配。

1. 通过将背靠法兰拉离工具将其拆下。

**注意：** 如果开启工具前未能正确放置砂轮，可能会对工具或砂轮造成损坏。

## 使用前的准备工作

- 安装防护罩及合适的圆盘或砂轮。禁止使用过度磨损的圆盘或砂轮。
- 确保内部和外部法兰已正确安装。请遵循**研磨和切割附件图表**中提供的说明。



- 确保圆盘或砂轮按附件和工具上的箭头方向转动。
- 请勿使用破损的附件。每次使用之前都要检查附件，例如，砂轮是否有碎片和裂痕。如果电动工具或附件跌落，请检查其是否受损，或者安装未受损的附件。检查并安装附件后，让自己和旁观者的位置远离旋转附件的平面，并以电动工具最大空载转速运转 1 分钟。受损附件通常会在此测试期间碎裂。

## 操作

### 使用说明



**警告：** 务必遵守安全指示和适用法规。



**警告：** 为降低严重的人身伤害风险，在进行任何调整或取出/安装附件或配件之前，请关闭工具电源和断开工具电源连接。请确保触发开关处于 OFF（关闭）位置。意外启动可能会导致人身伤害。



**警告：**

- 确保所有要磨削或切割的材料均已固定到位。
- 固定并支撑工件。使用夹具或老虎钳夹紧工件，并将其支撑在稳定的平台上。务必牢固地夹住和撑住工件以防止工件移动和失控。工件移动或失控可能会引发危险并导致人身伤害。
- 为板材或任何超大工件提供支撑可最大程度地降低砂轮卡住和反弹的风险。大工件容易因自身的重量而下陷。必须在工件下方靠近切割线处和砂轮两侧近工件边缘处放置支撑物。
- 操作此工具时始终佩戴普通工作手套。
- 齿轮箱在使用期间温度变得很高。
- 轻轻地对工具施加压力。切勿对磨片施加侧压力。
- 始终安装防护罩及合适的圆盘或砂轮。请勿使用过度磨损的圆盘或砂轮。
- 确保内部和外部法兰已正确安装。

- 确保圆盘或砂轮按附件和工具上的箭头方向转动。
- 避免过载。如果工具变得灼热，请让它在空载情况下运转几分钟以冷却附件。请勿在冷却前碰触附件。圆盘在使用时会变得非常热。
- 切勿在没有安装合适防护罩的情况下使用研磨盘。
- 请勿将电动工具与切割台搭配使用。
- 切勿将缓冲垫与固结研磨产品一起使用。
- 请注意，关闭工具后，锯轮会继续旋转。

### 正确的手持方式（图 G）



**警告：** 为降低严重的人身伤害风险，请务必使用正确的手持方式，如图所示。



**警告：** 为降低严重的人身伤害风险，请务必紧握工具以防止意外事件。

正确的手持方式要求一只手握住侧手柄 **3**，另一只手握紧工具主体，如图 G 所示。

### 扳机开关（图 A-1）



**警告：** 紧握工具侧手柄和主体以在启动时和使用过程中保持对工具的控制，直到砂轮或附件停止转动。确保砂轮完全停止后才放下工具。

**注：** 若要减少工具意外移动，请勿在负载情况下开启或关闭工具。允许角磨机运转达到全速后再接触工作表面。从工作表面提起工具，然后再关闭工具。允许工具停止转动后再将其放下。

1. 要开启工具，请朝工具背部推动锁止杆 **8**，然后按下扳机开关 **7**。按下开关时，工具将运行。
2. 要关闭工具，请松开触发开关。

### 开关锁钮（DWE8411和DWE8421）

开关锁钮 **11** 能提高长时间使用下的舒适度。要锁定工具，请在工具运行时按下开关锁钮。工具会在松开扳机开关后继续运行。要解锁工具，请按下次松开扳机开关。这会使工具停止运行。

## 滑动开关 (图 A-2) (DWE8410 和 DWE8420)

**警告：** 紧握工具侧手柄和主体以在启动时和使用过程中保持对工具的控制，直到砂轮或附件停止转动。确保砂轮完全停止后才放下工具。

**注：** 若要减少工具意外移动，请勿在负载情况下开启或关闭工具。允许角磨机运转达到全速后再接触工作表面。从工作表面提起工具，然后再关闭工具。允许工具停止转动后再将其放下。

**警告：** 将工具连接到电源之前，按下滑动开关的后部，然后松开，确保开关处于关闭位置。在工具的电源出现中断后，如激活接地故障断路器、丢弃断路器、意外拔下插头或断电，如上面所述确保滑动开关处于关闭位置。如果连接电源后滑动开关锁定为开启状态，工具将会意外启动。

若要启动工具，请将滑动开关  滑向工具的前方。要停止工具，请松开滑动开关。

要使工具连续运行，请将开关滑向工具的前方向内按开关的前部。若要在连续运行模式停止工具，请按下滑动开关的后部，然后松开。

## 主轴锁 (图 B)

主轴锁  可在安装或拆除砂轮时防止主轴转动。只能在工具关闭、拔出电源插头且完全停止时使用主轴锁。

**注意：** 为了降低工具损坏的风险，请勿在工具运转时使用主轴锁。否则将损坏工具，附着的附件可能会甩脱，从而导致伤害。

若要使用主轴锁，请按下主轴锁按钮并转动主轴，直到无法再转动为止。

## 表面磨削

**警告：** 务必按照本手册中的说明使用正确的防护罩。

**警告：** 金属粉尘积聚。在金属应用中过度使用砂轮片可能会增加触电的风险。若要降低此风险，使用前请插入 RCD，并每天清洁通风槽，按照以下维护说明将干燥的压缩空气吹入通风槽。

要在工件表面执行工作：

1. 让工具达到全速，然后再将工具放到工作表面。
2. 在工作表面上施加最小的压力，让工具在高速下运行。材料去除速度在工具于高速运行时最大。

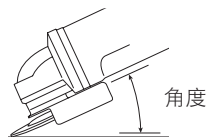

3. 在工具和工作表面之间保持适当的夹角。请按照特定功能参阅图表。

功能	角度
磨削	20°-30°

4. 让砂轮边缘与工作表面之间保持接触。
  - 如果要磨削、使用砂轮片磨砂，请前后持续移动工具，以避免在工作表面上产生沟槽。
  - 如果要使用靠背垫磨削，请不断按直线移动工具，以防止在工作表面留下灼热和旋动标记。

**注：** 让工具停在工作表面上不移动会使工件受损。

5. 从工作表面移开工具，然后再关闭工具。让工具停止转动后再将其放下。

**警告：** 在边缘操作时要特别注意，因为角磨机可能突然发生大幅运动。

## 边缘磨削和切割

**警告：** 不要将边缘磨削/切割砂轮用于表面磨削，因为这些砂轮自身的设计构造并不足以抵抗表面磨削所产生的侧压。这样可能会导致砂轮爆裂或人员受伤。

**警告：** 使用本工具时，若用于边缘磨削和切割的砂轮出现弯曲或扭曲，则可能导致碎裂或反弹。在所有边缘磨削/切割操作中，防护罩的开口侧均不得对着操作人员。

**注意：** 使用 27 型号砂轮的边缘磨削/切割范围必须限制为浅切割和开槽 - 新砂轮的深度小于 13 毫米。随着砂轮磨损，砂轮半径会缩短，切割/开槽深度也会降低。有关详细信息，请参阅附件图表。使用 41 型号砂轮进行边缘磨削/切割需要使用 1 型号防护罩。

1. 让工具达到全速，然后再将工具放到工作表面。
2. 在工作表面上施加最小的压力，让工具在高速下运行。磨削/切割速度在工具于高速下运行时最大。
3. 不要站在砂轮底面开口侧。
4. 一旦切割开始并在工件上形成了凹口，请勿改变切割角度。改变角度会造成砂轮弯曲，并可能导致砂轮破损。边缘磨削砂轮的设计不能耐受弯曲造成的侧压。
5. 从工作表面移开工具，然后再关闭工具。让工具停止转动后再将其放下。

## 金属应用

将工具用于金属加工时，确保已插入漏电保护器 (RCD) 以避免金属屑导致的剩余风险。

如果 RCD 切断电源，请将工具送交 DeWALT 授权维修代理。



**警告：**在极端工作条件下，处理金属时，机壳内部可能会积聚导电粉尘。这可能导致机器中的保护绝缘变弱，可能有触电的风险。

若要避免在机器内部积聚金属屑，我们建议每天清洁通风槽。请参阅 **维护**。

## 切割金属

**要剪切固结研磨产品，务必使用 1 类型防护罩。**

切割时，应适当进刀，并根据切割材料进行调整。

请勿在切割圆盘上施压、使机器倾斜或摆动。

请勿通过施加侧向压力来降低切割圆盘的运转速度。

机器必须始终以逆磨运动工作。否则会存在被推出切割位置导致失控的危险。

切割型材和方棒时，最好从最小的横截面开始切割。

## 粗研磨

**切勿使用切割圆盘进行粗研磨。**

**始终使用 27 型号防护罩。**

将机器角度设为 30° 到 40° 时，可实现最佳的粗研磨效果。施加适当压力，来回移动机器。这样，工件温度不会太高、不会变色也不会出现凹槽。

## 切割石材

**机器应该仅用于干式切割。**

对于切割石材，最好使用金刚切割圆盘。仅在使用额外防尘面罩时操作机器。

## 工作建议

**在结构墙上开槽时，请谨慎操作。**

在结构墙上开槽必须遵守国家/地区的相关法规。任何情况下都必须遵守这些法规。开始工作前，请咨询负责的结构工程师、建筑师或施工主管。

## 维护

DeWALT 电动工具设计精良，可以长时间使用，而且只需极少的维护。要持续获得令人满意的工作效果，需要进行合适的工具维护和定期清洁。



**警告：**为降低严重的人身伤害风险，在进行任何调整或取出/安装附件或配件之前，请关闭**机电源和断开工具电源连接**。请确保触发开关处于 OFF（关闭）位置。意外启动可能会导致人身伤害。

## 自停式碳刷

电机将自动关闭，指示碳刷快磨完，工具需要维修。碳刷不可由用户自行维修。请将工具送交 DeWALT 维修代理。



## 润滑

本电动工具无需另行润滑。



## 清洁



**警告：**一旦看到通风口及其周围积聚了尘屑，请用干燥的空气将灰尘和尘屑从主机外壳内吹出。执行此过程时，需戴上经认可的护目装备和防尘面具。



**警告：**切勿使用溶剂或其他刺激性化学制品来清洁工具的非金属部件。这些化学物质可能会削弱这些部位使用的材料。请用布蘸温和的肥皂水擦拭。切勿让任何液体渗入工具，切勿让工具的任何部件浸在液体中。



## 可选附件



**警告：**除了 DeWALT 提供的附件之外，其他附件都未经此产品兼容性测试，若将此类附件与本工具一起使用将存在安全隐患。为降低人身伤害风险，本产品只可使用 DeWALT 推荐的附件。

请向您的经销商咨询更多关于合适附件的信息。

	最大 [毫米]		[毫米]	最小 转速 [最小 值 <sup>-1</sup> ]	圆周 速度 [米/秒]	螺纹孔 长度 [毫米]
	D	b	d			
	115	6	22、23	11,500	80	-
	125	6	22、23	11,500	80	-
	150	6	22、23	9,500	80	-
	115	-	-	11,500	80	-
	125	-	-	11,500	80	-
	150	-	-	9,500	80	-

## 保护环境



分类回收。由此符号标记的产品和电池不得与普通家庭垃圾一起处理。

产品和电池包含可恢复或回收的材料，从而降低对原材料的需求。请根据当地供给回收电子产品和电池。为获得更多信息，请参看 [www.2helpU.com](http://www.2helpU.com)。

制造商：百得（苏州）科技有限公司

地址：苏州工业园区苏虹中路200号出口加工区

产地：江苏苏州