

DEWALT®

www.DEWALT.com

D28730
D28730D

English	3
简体中文	10
繁體中文	15
한국어	20
ภาษาไทย	26
TIẾNG VIỆT	33

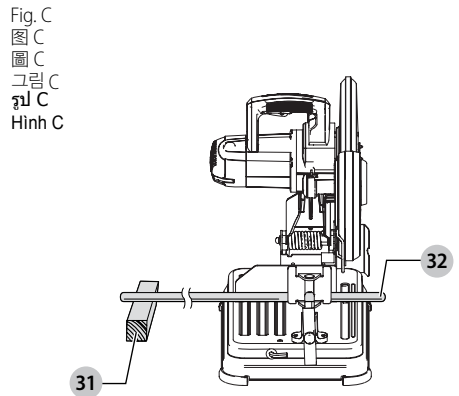
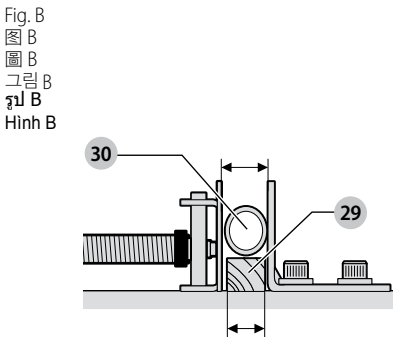
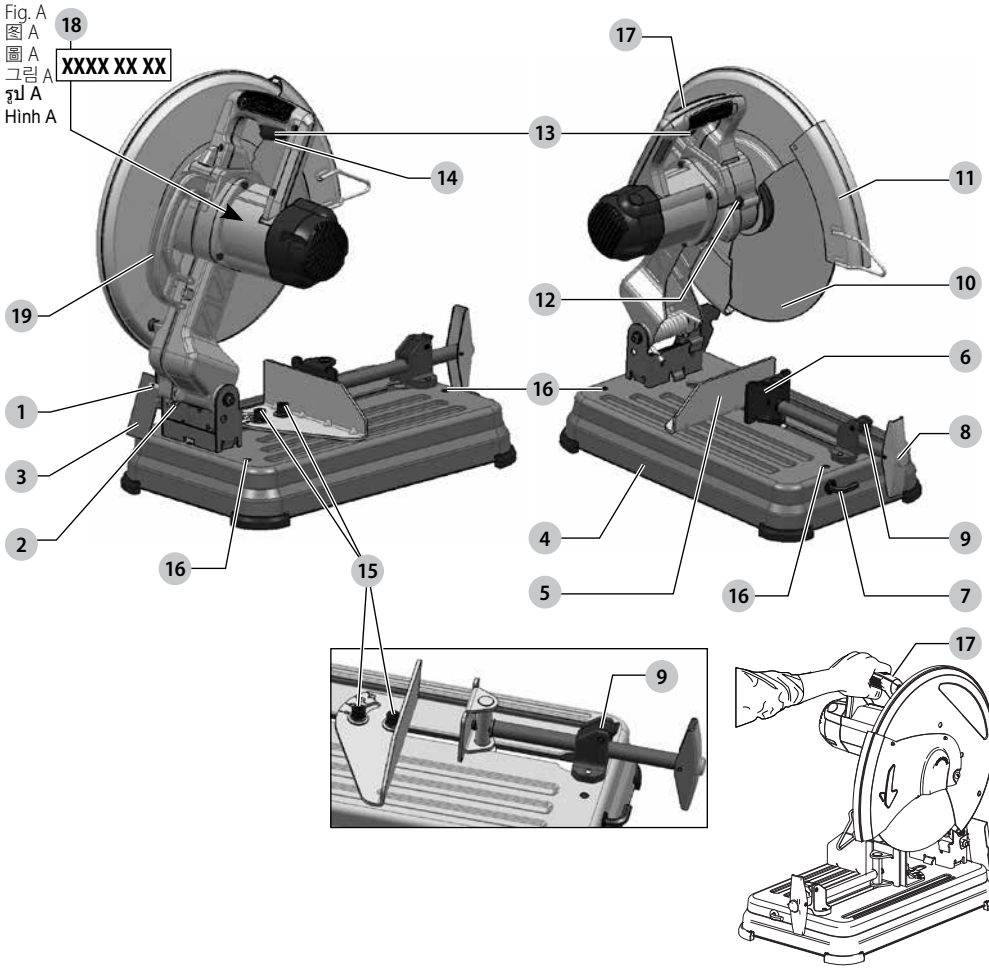

Fig. D
 图 D
 圖 D
 그림 D
 រូប D
 Hình D

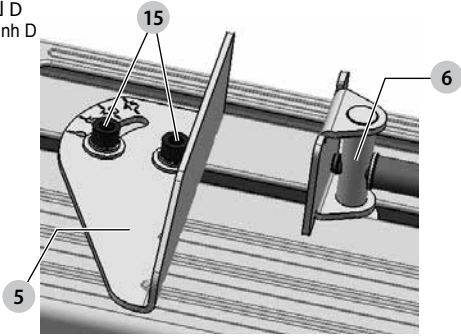

Fig. E
 图 E
 圖 E
 그림 E
 រូប E
 Hình E

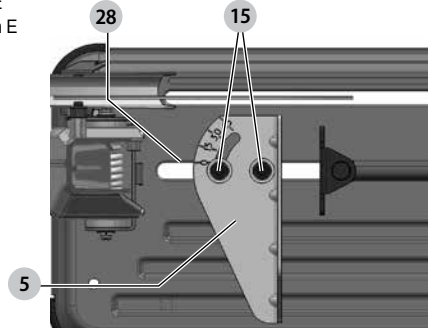

Fig. F
 图 F
 圖 F
 그림 F
 រូប F
 Hình F

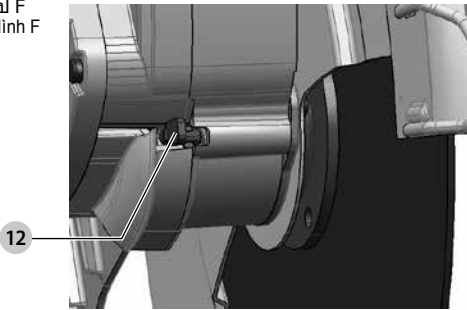

Fig. G
 图 G
 圖 G
 그림 G
 រូប G
 Hình G

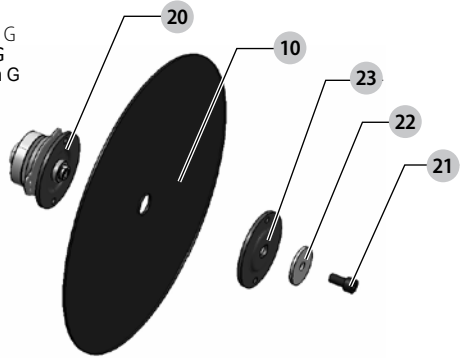

Fig. H
 图 H
 圖 H
 그림 H
 រូប H
 Hình H

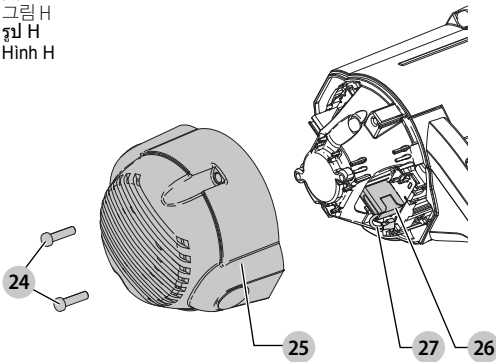
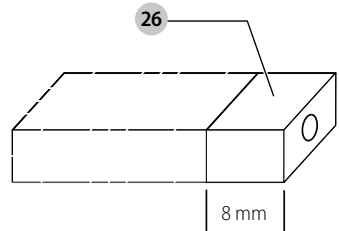

Fig. I
 图 I
 圖 I
 그림 I
 រូប I
 Hình I



CHOP SAW

D28730/D28730D

Congratulations!

You have chosen a DEWALT tool. Years of experience, thorough product development and innovation make DEWALT one of the most reliable partners for professional power tool users.

Technical Data

		D28730/D28730D
Voltage	V _{AC}	220–240
Power Input	W	2300
No-load speed	min ⁻¹	4000
Min. peripheral speed cutting disc	m/s	80
Disc diameter	mm	355
Disc bore	mm	25.4
Disc body thickness	mm	3.0
Thread size of spindle		M10
Type of cutting disc straight, non-recessed		
Cross-cutting capacity at 90°		
circular	mm	125
square	mm	115 x 115
rectangular	mm	115 x 130
angular	mm	120 x 120
Cross-cutting capacity at 45°		
circular	mm	115
square	mm	98 x 98
rectangular	mm	95 x 105
angular	mm	105 x 105
Weight	kg	15.5

Definitions: Safety Guidelines

The definitions below describe the level of severity for each signal word. Please read the manual and pay attention to these symbols.



DANGER: Indicates an imminently hazardous situation which, if not avoided, **will** result in **death or serious injury**.



WARNING: Indicates a potentially hazardous situation which, if not avoided, **could** result in **death or serious injury**.



CAUTION: Indicates a potentially hazardous situation which, if not avoided, **may** result in **minor or moderate injury**.

NOTICE: Indicates a practice **not related to personal injury** which, if not avoided, **may** result in **property damage**.



Denotes risk of electric shock.



Denotes risk of fire.

General Power Tool Safety Warnings



WARNING: Read all safety warnings, instructions, illustrations and specifications provided with this power tool. Failure to follow all instructions listed below may result in electric shock, fire and/or serious injury.

SAVE ALL WARNINGS AND INSTRUCTIONS FOR FUTURE REFERENCE

The term “power tool” in the warnings refers to your mains-operated (corded) power tool or battery-operated (cordless) power tool.

1) Work Area Safety

- Keep work area clean and well lit.** Cluttered or dark areas invite accidents.
- Do not operate power tools in explosive atmospheres, such as in the presence of flammable liquids, gases or dust.** Power tools create sparks which may ignite the dust or fumes.
- Keep children and bystanders away while operating a power tool.** Distractions can cause you to lose control.

2) Electrical Safety

- Power tool plugs must match the outlet. Never modify the plug in any way. Do not use any adapter plugs with earthed (grounded) power tools.** Unmodified plugs and matching outlets will reduce risk of electric shock.
- Avoid body contact with earthed or grounded surfaces such as pipes, radiators, ranges and refrigerators.** There is an increased risk of electric shock if your body is earthed or grounded.
- Do not expose power tools to rain or wet conditions.** Water entering a power tool will increase the risk of electric shock.
- Do not abuse the cord. Never use the cord for carrying, pulling or unplugging the power tool. Keep cord away from heat, oil, sharp edges or moving parts.** Damaged or entangled cords increase the risk of electric shock.
- When operating a power tool outdoors, use an extension cord suitable for outdoor use.** Use of a cord suitable for outdoor use reduces the risk of electric shock.
- If operating a power tool in a damp location is unavoidable, use a ground fault circuit interrupter (GFCI) protected supply.** Use of a GFCI reduces the risk of electric shock.

3) Personal Safety

- Stay alert, watch what you are doing and use common sense when operating a power tool. Do not use a power tool while you are tired or under the influence of drugs, alcohol or medication.** A moment

of inattention while operating power tools may result in serious personal injury.

- b) **Use personal protective equipment. Always wear eye protection.** Protective equipment such as a dust mask, non-skid safety shoes, hard hat, or hearing protection used for appropriate conditions will reduce personal injuries.
- c) **Prevent unintentional starting. Ensure the switch is in the off-position before connecting to power source and/or battery pack, picking up or carrying the tool.** Carrying power tools with your finger on the switch or energising power tools that have the switch on invites accidents.
- d) **Remove any adjusting key or wrench before turning the power tool on.** A wrench or a key left attached to a rotating part of the power tool may result in personal injury.
- e) **Do not overreach. Keep proper footing and balance at all times.** This enables better control of the power tool in unexpected situations.
- f) **Dress properly. Do not wear loose clothing or jewellery. Keep your hair, clothing and gloves away from moving parts.** Loose clothes, jewellery or long hair can be caught in moving parts.
- g) **If devices are provided for the connection of dust extraction and collection facilities, ensure these are connected and properly used.** Use of dust collection can reduce dust-related hazards.
- h) **Do not let familiarity gained from frequent use of tools allow you to become complacent and ignore tool safety principles.** A careless action can cause severe injury within a fraction of a second.

4) Power Tool Use and Care

- a) **Do not force the power tool. Use the correct power tool for your application.** The correct power tool will do the job better and safer at the rate for which it was designed.
- b) **Do not use the power tool if the switch does not turn it on and off.** Any power tool that cannot be controlled with the switch is dangerous and must be repaired.
- c) **Disconnect the plug from the power source and/or the battery pack, if detachable, from the power tool before making any adjustments, changing accessories, or storing power tools.** Such preventive safety measures reduce the risk of starting the power tool accidentally.
- d) **Store idle power tools out of the reach of children and do not allow persons unfamiliar with the power tool or these instructions to operate the power tool.** Power tools are dangerous in the hands of untrained users.
- e) **Maintain power tools. Check for misalignment or binding of moving parts, breakage of parts and any other condition that may affect the power tool's operation. If damaged, have the power tool repaired before use.** Many accidents are caused by poorly maintained power tools.

- f) **Keep cutting tools sharp and clean.** Properly maintained cutting tools with sharp cutting edges are less likely to bind and are easier to control.
- g) **Use the power tool, accessories and tool bits, etc. in accordance with these instructions, taking into account the working conditions and the work to be performed.** Use of the power tool for operations different from those intended could result in a hazardous situation.
- h) **Keep handles and grasping surfaces dry, clean and free from oil and grease.** Slippery handles and grasping surfaces do not allow for safe handling and control of the tool in unexpected situations.

5) Service

- a) **Have your power tool serviced by a qualified repair person using only identical replacement parts.** This will ensure that the safety of the power tool is maintained.

Safety Instructions for Cut-off Machines

1) Cut-off Machine Safety Warnings

- a) **Position yourself and bystanders away from the plane of the rotating wheel.** The guard helps to protect the operator from broken wheel fragments and accidental contact with wheel.
- b) **Use only bonded reinforced or diamond cut-off wheels for your power tool.** Just because an accessory can be attached to your power tool, it does not assure safe operation.
- c) **The rated speed of the accessory must be at least equal to the maximum speed marked on the power tool.** Accessories running faster than their rated speed can break and fly apart.
- d) **Wheels must be used only for recommended applications. For example: do not grind with the side of a cut-off wheel.** Abrasive cut-off wheels are intended for peripheral grinding, side forces applied to these wheels may cause them to shatter.
- e) **Always use undamaged wheel flanges that are of correct diameter for your selected wheel.** Proper wheel flanges support the wheel thus reducing the possibility of wheel breakage.
- f) **The outside diameter and the thickness of your accessory must be within the capacity rating of your power tool.** Incorrectly sized accessories cannot be adequately guarded or controlled.
- g) **The arbour size of wheels and flanges must properly fit the spindle of the power tool.** Wheels and flanges with arbour holes that do not match the mounting hardware of the power tool will run out of balance, vibrate excessively and may cause loss of control.
- h) **Do not use damaged wheels. Before each use, inspect the wheels for chips and cracks. If the power tool or wheel is dropped, inspect for damage or install an undamaged wheel. After inspecting and installing the wheel, position yourself and bystanders away from the plane of the rotating wheel and run the power tool at maximum no load**

speed for one minute. Damaged wheels will normally break apart during this test time.

- i) **Wear personal protective equipment. Depending on application, use face shield, safety goggles or safety glasses. As appropriate, wear a dust mask, hearing protectors, gloves and shop apron capable of stopping small abrasive or workpiece fragments.** The eye protection must be capable of stopping flying debris generated by various operations. The dust mask or respirator must be capable of filtering particles generated by your operation. Prolonged exposure to high intensity noise may cause hearing loss.
- j) **Keep bystanders a safe distance away from work area. Anyone entering the work area must wear personal protective equipment.** Fragments of workpiece or of a broken wheel may fly away and cause injury beyond immediate area of operation.
- k) **Position the cord clear of the spinning accessory.** If you lose control, the cord may be cut or snagged and your hand or arm may be pulled into the spinning wheel.
- l) **Regularly clean the power tool's air vents.** The motor's fan can draw the dust inside the housing and excessive accumulation of powdered metal may cause electrical hazards.
- m) **Do not operate the power tool near flammable materials. Do not operate the power tool while placed on a combustible surface such as wood.** Sparks could ignite these materials.
- n) **Do not use accessories that require liquid coolants.** Using water or other liquid coolants may result in electrocution or shock.

Kickback and Related warnings

Kickback is a sudden reaction to a pinched or snagged rotating wheel. Pinching or snagging causes rapid stalling of the rotating wheel which in turn causes the uncontrolled cutting unit to be forced upwards toward the operator.

For example, if an abrasive wheel is snagged or pinched by the workpiece, the edge of the wheel that is entering into the pinch point can dig into the surface of the material causing the wheel to climb out or kick out. Abrasive wheels may also break under these conditions.

Kickback is the result of power tool misuse and/or incorrect operating procedures or conditions and can be avoided by taking proper precautions as given below.

- a) **Maintain a firm grip on the power tool and position your body and arm to allow you to resist kickback forces.** The operator can control upward kickback forces, if proper precautions are taken.
- b) **Do not position your body in line with the rotating wheel.** If kickback occurs, it will propel the cutting unit upwards toward the operator.
- c) **Do not attach a saw chain, woodcarving blade, segmented diamond wheel with a peripheral gap greater than 10 mm or toothed saw blade.** Such blades create frequent kickback and loss of control.

- d) **Do not "jam" the wheel or apply excessive pressure. Do not attempt to make an excessive depth of cut.** Overstressing the wheel increases the loading and susceptibility to twisting or binding of the wheel in the cut and the possibility of kickback or wheel breakage.
- e) **When the wheel is binding or when interrupting a cut for any reason, switch off the power tool and hold the cutting unit motionless until the wheel comes to a complete stop. Never attempt to remove the wheel from the cut while the wheel is in motion otherwise kickback may occur.** Investigate and take corrective action to eliminate the cause of wheel binding.
- f) **Do not restart the cutting operation in the workpiece. Let the wheel reach full speed and carefully re-enter the cut.** The wheel may bind, walk up or kickback if the power tool is restarted in the workpiece.
- g) **Support any oversized workpiece to minimize the risk of wheel pinching and kickback.** Large workpieces tend to sag under their own weight. Supports must be placed under the workpiece near the line of cut and near the edge of the workpiece on both sides of the wheel.

Additional Safety Warnings for Chop Saws

- In operation, avoid bouncing the cutting disc or giving it rough treatment. If this occurs, stop the tool and inspect the cutting disc.
- Do not operate the tool while standing in line with the cutting disc. Keep other persons away from the work area.
- Be aware of cutting chips and the material being cut. They may be sharp and hot. Allow cut off parts to cool before handling.
- The spark deflector becomes hot during use. Avoid touching or adjusting the spark deflector or immediately after operation.
- Switch off the tool and wait for the cutting disc to stop before moving the workpiece or changing the settings.
- After switching off, never attempt to stop the cutting disc by pressing against the side of the disc.
- Do not use cutting fluids. These fluids could ignite or cause electrical shock.
- Check that the workpiece is properly supported.
- Use the cutting discs recommended by the manufacturer only. Do not use tools for purposes not intended; for example do not use circular saw blade to cut tree limbs or logs.
- The max. allowable speed of the cutting disc must always be equal to or greater than the no-load speed of the tool specified on the nameplate.
- Do not use cutting discs that do not conform to the dimensions stated in the **Technical Data**.
- Read the operating instructions supplied by the wheel manufacturer.
- Ensure that the abrasive wheel is correctly fitted and tightened before use.
- Let the tool run at no-load in a safe position for at least 30 seconds. If there is a considerable vibration or if any

other defect occurs, stop the tool and check it to determine the cause.

- Do not use cutting discs for side grinding.
- Do not cut concrete, brick, tile or ceramic materials.
- Do not cut wood, plastic or synthetic materials.
- Do not cut cast-iron materials.
- Never cut magnesium materials.
- Do not cut electrically live material.
- Use this tool in a well-ventilated area. Do not operate the tool near flammable liquids, gases or dust. Sparks or hot chips from cutting or arcing motor brushes may ignite combustible materials.
- Regularly clear the ventilation slots when working in dusty conditions. If it should become necessary to clean the slots, always use a soft brush; remember to unplug the machine first.
- Always store cutting discs well-protected and in a dry place, out of reach of children.
- Check damaged parts. Before further use of the tool, a guard or other part that is damaged should be carefully checked to determine that it will operate properly and perform its intended function—check for alignment of moving parts, binding of moving parts, breakage of parts, mounting, and any other conditions that may affect its operation. A guard or other part that is damaged should be properly repaired or replaced.

Residual Risks

- The following risks are inherent to the use of these machines:
 - я injuries caused by touching the rotating parts.
 - я injuries caused by disruption of the cutting disc.
- These risks are most evident:
 - я within the range of operation
 - я within the range of the rotating machine parts
- In spite of the application of the relevant safety regulations and the implementation of safety devices, certain residual risks cannot be avoided. These are:
 - я Impairment of hearing.
 - я Risk of accidents caused by the uncovered parts of the rotating cutting disc.
 - я Risk of injury when changing the disc.
 - я Risk of squeezing fingers when opening the guards.

Electrical Safety

The electric motor has been designed for one voltage only. Always check that the power supply corresponds to the voltage on the rating plate.



Your DEWALT tool is double insulated in accordance with IEC62841; therefore no earth wire is required.



WARNING: 115 V units have to be operated via a fail-safe isolating transformer with an earth screen between the primary and secondary winding.

If the supply cord is damaged, it must be replaced by a specially prepared cord available through the DEWALT service organisation.

Voltage Drops

Inrush currents cause short-time voltage drops. Under unfavourable power supply conditions, other equipment may be affected.

If the system impedance of the power supply is lower than 0.11 Ω, disturbances are unlikely to occur.

Using an Extension Cable

If an extension cable is required, use an approved 3-core extension cable suitable for the power input of this tool (see **Technical Data**). The minimum conductor size is 1.5 mm²; the maximum length is 30 m.

When using a cable reel, always unwind the cable completely.

Package Contents

The package contains:

- 1 Chopsaw
- 1 Abrasive wheel
- 1 Hex key
- 1 Instruction manual

- Check for damage to the tool, parts or accessories which may have occurred during transport.
- Take the time to thoroughly read and understand this manual prior to operation.

Markings on Tool

The following pictograms are shown on the tool:



Read instruction manual before use.



Wear ear protection.



Wear eye protection.



Bore Diameter



Direction of rotation

Date Code Position (Fig. A)

The date code **18** which also includes the year of manufacture, is printed into the housing.

Example:

2019 XX XX

Year of Manufacture

Description (Fig. A)

WARNING: Never modify the power tool or any part of it. Damage or personal injury could result.

- | | |
|-------------------------|----------------------------|
| 1 Lock pin | 11 Guard |
| 2 Spark deflector screw | 12 Spindle lock |
| 3 Spark deflector | 13 Lock-off trigger switch |
| 4 Base | 14 Lock-off lever |
| 5 Fence | 15 Fence bolts |
| 6 Vise | 16 Mounting holes |
| 7 8 mm hex key | 17 Operating handle |
| 8 Crank | 18 Date code |
| 9 Vise lever | 19 Carrying handle |
| 10 Wheel | |

Intended Use

Your D28730/D28730D chop saw has been designed for the cutting of variously shaped steel materials. It is designed only for use with reinforced bonded abrasives. Diamond or TCT blades should not be used with this unit.

DO NOT use under wet conditions or in the presence of flammable liquids or gases.

The D28730 chop saw is a professional power tool.

DO NOT let children come into contact with the tool. Supervision is required when inexperienced operators use this tool.

- **Young children and the infirm.** This appliance is not intended for use by young children or infirm persons without supervision.
- This product is not intended for use by persons (including children) suffering from diminished physical, sensory or mental abilities; lack of experience, knowledge or skills unless they are supervised by a person responsible for their safety. Children should never be left alone with this product.

ASSEMBLY AND ADJUSTMENTS





WARNING: To reduce the risk of serious personal injury, turn tool off and disconnect tool from power source before making any adjustments or removing/installing attachments or accessories. Be sure the trigger switch is in the OFF position. An accidental start-up can cause injury.

Cutting Capacity

The wide vise opening and high pivot point provide cutting capacity for many large pieces. Use the cutting capacity chart to determine total maximum size of cuts that can be made with a new wheel.

CAUTION: Certain large, circular or irregularly shaped objects may require additional holding means if they cannot be held securely in vise.

CAUTION: DO NOT CUT MAGNESIUM, WOOD, BRICK OR CONCRETE WITH THIS TOOL.

Workpiece Shape				
90° Cutting angle	A = 125 mm	A = 115 mm	115 mm x 130 mm	120 mm
45° Cutting angle	A = 115 mm	A = 98 mm	95 mm x 105 mm	105 mm

OPERATION

Instructions for Use

WARNING: Always observe the safety instructions and applicable regulations.

WARNING: To reduce the risk of serious personal injury, turn tool off and disconnect tool from power source before making any adjustments or removing/installing attachments or accessories. Be sure the trigger switch is in the OFF position. An accidental start-up can cause injury.

Proper Hand Position (Fig. A)

WARNING: To reduce the risk of serious personal injury, Always use proper hand position as shown.

WARNING: To reduce the risk of serious personal injury, always hold securely in anticipation of a sudden reaction.

Proper hand position requires one hand on the operating handle 17.

To Carry (Fig. A)

Fold down unit to position where you can carry the saw. Push in the lock pin 1 to lock the arm down. Always carry the saw using the carrying handle 19.

Unlocking (Fig. A)

To unlock tool and raise head, depress motor arm slightly and pull lock pin 1 out. Motor arm will then pivot upward.

Mounting (Fig. A)

CAUTION: Tool must be supported on stable, level, non-skid surface to prevent unexpected movement when operating.

1. Drill holes through the work surface that align the base of the chop saw.
2. Insert two M10 bolts down through the mounting holes 16 in the base and through holes in mounting surface. The approximate length of the screws should be the thickness of the mounting surface plus 102 mm.

Spark Deflector Adjustment (Fig. A)

WARNING: Do not touch the spark deflector during or immediately after operation as it becomes hot and may cause skin burn.

To best deflect sparks away from surrounding persons and materials, loosen the spark deflector screw **2**, adjust the spark deflector **3** and then retighten screw. Do not allow cordset to come into contact with deflector or sparks as damage to cordset may occur.

Trigger Switch (Fig. A)

To start the tool, depress the trigger switch **13**. To turn the tool off, release the trigger switch. Keep hands and material from wheel until it has coasted to a stop. To prevent unauthorized use of tool, install a standard padlock (not included) into the padlock hole **14** located in the trigger. There is provision for locking the switch on.

Material Clamping and Supporting (Fig. B, C)

- Angles are best clamped and cut with both legs resting against base.
- A spacer block **29** slightly narrower than the workpiece **30** can be used to increase wheel utilization (Fig. B).
- Long workpieces must be supported by a block **31** so it will be level with top of base (Fig. C). The cut-off end **32** should be free to fall downward to avoid wheel binding.

Vise Operation (Fig. A, D)

The vise has a quick travel feature. To release the vise **6** when it is clamped tightly, turn the crank **8** counterclockwise one or two times to remove clamping pressure. Lift the vise lever **9** up. Pull crank assembly out as far as desired. The vise may be shoved into work without cranking. Lower vise lever then tighten vise on work by using crank.

Fence Operation (Fig. A, D, E)

WARNING: Turn off and unplug the tool before making any adjustments or removing or installing attachments or accessories. Be sure the trigger switch is in the OFF position.

The fence **5** can be adjusted two ways: to change desired cutting angle and to change spacing between the fence and vise.

To Change the Desired Cutting Angle

Use the 8 mm hex key **7** provided to loosen (do not remove) the two fence bolts **15**. Align the desired angle indicator line with the slot line **28** in the base **4**. Securely tighten both fence bolts before use. For more accurate square cuts, disconnect the power supply, loosen the two fence bolts, push arm down until wheel extends into base. Place a square against the wheel and adjust fence against the square. Securely tighten both fence bolts before use. When making a miter cut, the vise **6** may not clamp securely, depending on the thickness of the workpiece and the miter angle. Other aids (such as spring, bar or C-clamps) will be necessary to secure the workpiece to the fence when making these cuts.

Removal and Installation of Wheels

(Fig. F, G)

WARNING: To reduce the risk of serious personal injury, turn tool off and disconnect tool from power source before making any adjustments or removing/ installing attachments or accessories. Do not make any adjustment while the wheel is in motion. Do not make any adjustment while chop saw is plugged into power supply.

WARNING: Always use gloves when handling wheels.

WARNING: Do not impact the wheel, and do not use a wheel that has been dropped or impacted. Do not use a chipped, deformed or damaged wheel.

1. Push in spindle lock **12** and rotate wheel **10** by hand until wheel lock lever engages slot in inside flange **20** to lock wheel. Loosen the bolt **21** counterclockwise in the center of the abrasive wheel with the 8 mm hex key **7**. Bolt has right-hand thread.
2. Remove the bolt **21**, washer **22**, outside flange **23** and old wheel **10**.
3. Make sure flange surfaces are clean and flat. Install the new abrasive wheel by reversing the above steps.
4. For safe operation, securely tighten bolt **21** to firmly secure the abrasive wheel **10** in between inner **20** and outer flanges **23**. Do not overtighten bolt **21**.

WARNING: Check the work surface that the chop saw rests on when replacing with a new abrasive wheel. It is possible that the wheel may contact ANY ITEMS OR STRUCTURE THAT EXTENDS ABOVE work surface (under the base) when the arm is fully lowered.

Soft Start Feature (D28730D only)

The soft start feature (Time Delay Relay--TDR) allows a slow speed run-up over 300 ms to avoid an initial jerk when starting. This feature is also particularly useful when the installed fuse value is too low or not of inert character.

Operation Tips for More Accurate Cuts

- Allow the wheel to do the cutting. Excessive force will cause the wheel to glaze reducing cutting efficiency and/or to deflect causing inaccurate cuts.
- Properly adjust fence angle.
- Make sure material is laying flat across base.
- Properly clamp material to avoid movement and vibration.

Motor Brush Inspection and Replacement (Fig. H, I)

BE SURE TOOL IS UNPLUGGED BEFORE INSPECTING BRUSHES. Brushes should be regularly inspected for wear. To inspect brushes, unscrew the two end cap screws **24** and remove the end cap **25**. To remove each brush **26**, first unplug the shunt wire **27** terminal connection. Then carefully back the brush spring out of the brush box and remove brush. Brushes should

slide freely in brush box. If brushes are worn down to 8 mm as shown in Figure 1, they should be replaced.

To reinstall each brush, carefully back the spring out of the brush box, insert the brush and return the spring making sure it is pressing on the brush and not touching the brush box. Reconnect shunt wire terminal, then replace the end cap and two screws.

MAINTENANCE

Your DEWALT power tool has been designed to operate over a long period of time with a minimum of maintenance. Continuous satisfactory operation depends upon proper tool care and regular cleaning.



WARNING: *To reduce the risk of serious personal injury, turn tool off and disconnect tool from power source before making any adjustments or removing/installing attachments or accessories. Be sure the trigger switch is in the OFF position. An accidental start-up can cause injury.*



Lubrication

Closed-type, grease-sealed ball bearings are used throughout. These bearings have sufficient lubrication packed in them at the factory to last the life of the chop saw.



Cleaning



WARNING: *Blow dirt and dust out of the main housing with dry air as often as dirt is seen collecting in and around the air vents. Wear approved eye protection and approved dust mask when performing this procedure.*



WARNING: *Never use solvents or other harsh chemicals for cleaning the non-metallic parts of the tool. These chemicals may weaken the materials used in these parts. Use a cloth dampened only with water and mild soap. Never let any liquid get inside the tool; never immerse any part of the tool into a liquid.*

Optional Accessories



WARNING: *Since accessories, other than those offered by DEWALT, have not been tested with this product, use of such accessories with this tool could be hazardous. To reduce the risk of injury, only DEWALT recommended accessories should be used with this product.*

Consult your dealer for further information on the appropriate accessories.

Use only high-strength Type 1 organic bonded wheels rated 4100 rpm or higher according to EN12413, safety requirements for bonded abrasive products.

Protecting the Environment



Separate collection. Products and batteries marked with this symbol must not be disposed of with normal household waste.



Products and batteries contain materials that can be recovered or recycled reducing the demand for raw materials. Please recycle electrical products and batteries according to local provisions. Further information is available at www.2helpU.com.

型材切割机

D28730

恭喜!

感谢您选购 DeWALT 工具。凭借多年的产品开发和创新能力，DeWALT 已经成为专业电动工具用户最可靠的合作伙伴之一。

技术参数

		D28730
电压	伏特 ^{交流}	220-240
输入功率	瓦	2300
空载转速	转/分	4000
最小圆周速度圆盘刀	米/秒	80
圆盘直径	毫米	355
圆盘孔	毫米	25.4
圆盘体厚度	毫米	3.0
主轴螺纹尺寸		M10
圆盘刀类型, 直形非嵌入式		
90° 的横切能力		
圆形	毫米	125
方形	毫米	115 x 115
矩形	毫米	115 x 130
角形	毫米	120 x 120
45° 的横切能力		
圆形	毫米	115
方形	毫米	98 x 98
矩形	毫米	95 x 105
角形	毫米	105 x 105
重量	千克	15.5

定义: 安全指南

下列定义描述了各标志术语的严重程度。请仔细阅读本手册, 并注意这些标志。

 **危险:** 表示存在紧急危险情况, 如果不加以避免, 将导致死亡或严重伤害。

 **警告:** 表示存在潜在的危险情况, 如果不加以避免, 可能导致死亡或严重伤害。

 **警告:** 表示存在潜在危险情况, 如果不加以避免, 可能导致轻度或中度伤害。

注意: 表示存在在不涉及人身伤害的情况, 如果不加以避免, 可能导致财产损失。

 表示存在触电风险。

 表示存在火灾风险。

电动工具通用安全警告

 **警告!** 阅读所有警告和所有说明。不遵照以下警告和说明会导致电击、着火和/或严重伤害。

保存所有警告和说明书以备查阅。

在所有下列的警告中术语“电动工具”指市电驱动(有线)电动工具或电池驱动(无线)电动工具。

a) 工作场地的安全

- 1) 保持工作场地清洁和明亮。混乱和黑暗的场地会引发事故。
- 2) 不要在易爆环境, 如有易燃液体、气体或粉尘的环境下操作电动工具。电动工具产生的火花会点燃粉尘或气体。
- 3) 让儿童和旁观者离开后操纵电动工具。注意力不集中会使你失去对工具的控制。

b) 电气安全

- 1) 电动工具插头必须与插座相配。绝不能以任何方式改装插头。需接地的电动工具不能使用任何转换插头。未经改装的插头和相配的插座将减少电击风险。
- 2) 避免人体接触接地表面, 如管道、散热片和冰箱。如果你身体接地会增加电击危险。
- 3) 不得将电动工具暴露在雨或潮湿环境中。水进入电动工具将增加电击危险。
- 4) 不得滥用电线。绝不能用电线搬运、拉动电动工具或拔出其插头。使电线远离热源、油、锐边或运动部件。受损或缠绕的软线会增加电击危险。
- 5) 当在户外使用电动工具时, 使用适合户外使用的外接电线。适合户外使用的电线将降低电击危险。
- 6) 如果电动工具处于潮湿环境是不可避免的, 应使用剩余电流动作保护器。RCD 的使用可降低电击风险。

c) 人身安全

- 1) 保持警觉, 当操作电动工具时关注所从事的操作并保持清醒。当操作者感到疲倦, 或在有药物、酒精或治疗反应时, 不要操作电动工具。在操作电动工具时瞬间的疏忽会导致严重人身伤害。
- 2) 使用个人防护装置。始终佩戴护目镜。安全装置, 诸如适当条件下使用防全面具、防滑安全鞋、安全帽、听力防护等装置能减少人身伤害。
- 3) 防止意外启动。确保开关在连接电源和/或电池盒、拿起或搬运工具时处于关断位置。手指放在已接通电源的开关上或开关处于接通时插入插头可能会导致危险。
- 4) 在电动工具接通之前, 拿掉所有调节钥匙或扳手。遗留在电动工具旋转零件上的扳手或钥匙会导致人身伤害。
- 5) 手不要伸展得太长。时刻注意立足点和身体平衡。这样在意外情况下能很好地控制电动工具。
- 6) 着装适当。不要穿宽松衣服或佩戴饰品。让你的衣服、手套和头发远离运动部件。宽松衣服、配饰或长发可能会卷入运动部件。
- 7) 保持手干燥、清洁且没有油脂。油腻的手柄对于意外情况下的工具安全握持和控制是不允许的。
- 8) 如果提供了与排屑、集尘设备连接用的装置, 要确保他们连接完好且使用得当。使用这些装置可减少尘屑引起的危险。

d) 电动工具使用和注意事项

- 1) 不要滥用过载使用电动工具，根据用途使用合适的电动工具。选用适当的设计额定值的电动工具会使操作者工作更有效、更安全。
- 2) 如果开关不能接通或关断工具电源，则不能使用该电动工具。不能用开关来控制的电动工具是危险的且必须进行修理。
- 3) 在进行任何调节、更换附件或贮存电动工具之前，必须从电源上拔掉插头。这种防护性措施将减少电动工具意外起动的危险。
- 4) 将闲置不用的电动工具贮存在儿童所及范围之外，并且不要让不熟悉电动工具或对这些说明不了解的人操作电动工具。电动工具在未经培训训练的用户手中是危险的。
- 5) 保养电动工具。检查运动件是否调整到位或卡住，检查零件破损情况和影响电动工具运行的其他状况。如有损坏，电动工具应在使用前修理好。许多事故由维护不良的电动工具引发。
- 6) 保持切削刀具锋利和清洁。保养良好的有锋利切削刃的刀具不易卡住而且容易控制。
- 7) 按照使用说明，考虑作业条件和进行的作业来使用电动工具、附件和工具的刀头等。将电动工具用于那些与其用途不符的操作可能会导致危险情况。

e) 维修

将电动工具送交专业维修人员，必须使用同样的备件进行更换。这样将确保所维修的电动工具的安全性。

型材切割机 chop saw 专用警告语：

- 佩戴护目镜；
- 不要使用损坏的砂轮；
- 不要使用在适当位置上没有护罩的型材切割机；
- 只允许使用制造厂推荐的砂轮，其标明的速度等于或大于工具上标明的速度；
- 阅读砂轮制造厂提供的使用说明。

切割机安全指示

1) 切割机安全警告

- a) 保持身体远离旋转轮的平面，并且勿使旁观者靠近。护罩有助于保护操作人员免于受到爆裂砂轮碎片和意外触及砂轮的危险。
- b) 电动工具仅可使用固结加筋或金刚切割砂轮。这是因为附件即使能安装到工具上但也无法确保安全操作。
- c) 附件的额定转速必须至少达到电动工具上标示的最大转速。附件以比其额定转速大的转速运转会发生爆裂和飞溅。
- d) 砂轮只用于推荐的用途。例如，不要使用切割砂轮的侧面进行磨削。磨切砂轮设计用于圆周磨削，对砂轮侧面施力可能会使其碎裂。
- e) 始终为所选砂轮选用未损坏的、直径适合的砂轮法兰盘。合适的砂轮法兰盘支撑砂轮可以减小砂轮破裂的可能性。
- f) 附件的外径和厚度必须在电动工具的额定能力范围内。不正确的附件尺寸不能得到充分防护或控制。
- g) 砂轮和法兰的轴孔尺寸必须适合电动工具的主轴。砂轮和法兰的轴孔若与电动工具安装件不相配会导致失稳、过度震动并且可能会引起失控。

- h) 请勿使用破损的砂轮。每次使用之前，请检查砂轮是否有缺口和裂缝。如果电动工具或砂轮跌落，请检查其是否受损，或者安装未受损的砂轮。检查并安装砂轮后，您本人和旁观者需要远离旋转砂轮的平面，并且让电动工具以最大空载转速运行一分钟。受损砂轮通常会在此测试期间碎裂。
- i) 佩戴个人防护装备。根据适用情况，使用面罩、安全护目镜或防护眼镜。适当情况下，戴上防尘面罩、听力保护器、手套和能阻挡细小磨料或工件碎片的工作围裙。护目装备必须能够挡住各种操作产生的飞屑。防尘面具或口罩必须能够过滤操作产生的颗粒。长期暴露在高强度噪声中会引起失聪。
- j) 让旁观者与工作区域保持一定安全距离。任何进入工作区域的人必须戴上防护用品。工件或破损砂轮的碎片可能会飞出并导致紧邻操作区域的旁观者受伤。
- k) 使软线远离旋转的附件。如果控制不当，电线可能被切断或缠绕，并使您的手或手臂可能被卷入旋转砂轮中。
- l) 经常清理电动工具的通风口。电动机风扇会将灰尘吸进机壳，过多的金属粉尘沉积可能会导致电气危险。
- m) 不要在易燃材料附近操作电动工具。放置于易燃表面(如木材)上时，请勿操作该电动工具。火星可能会点燃这些材料。
- n) 不要使用需用冷却液的附件。用水或其他冷却液可能会导致触电或电击。

反弹和相关警告

反冲是因卡住或缠绕住的旋转砂轮产生的突然反作用力。卡住或缠绕会引起旋转轮的迅速堵转，随之使失控的切割装置被向上推往操作员。

例如，如果砂轮被工件缠绕或卡住，伸入卡住点的砂轮边缘可能会进入材料表面而引起砂轮爬出或反弹。在这些条件下砂轮也可能碎裂。

反弹是由于电动工具使用不当和/或不正确的操作工序或环境造成的，采取以下适当的预防措施可避免反冲现象：

- a) 保持紧握电动工具，使您的身体和手臂处于正确状态以抵抗反冲力。如果采取合适的预防措施，操作员就可以控制向上的反弹力。
- b) 身体不要对着旋转的砂轮。如果发生反冲，则会将切割装置向上推往操作员。
- c) 请勿附接周边间隙超过 10 毫米或带有齿形锯片的锯条、木雕锯片、节状金刚轮。此类锯片会产生频繁的反弹和失控。
- d) 不要“挤压”砂轮或对其施加过大的压力。不要试图切割过深。对砂轮过度施压会增加负载，使砂轮在切割时更容易扭曲或卡住，而且还会增大反冲或砂轮爆裂的可能性。
- e) 当砂轮被卡住或因任何原因而中断切割时，请切断电动工具的电源并握住切割装置不动，直到砂轮完全停止。切勿试图在砂轮仍在运行时使砂轮脱离切割体，否则会发生反冲。检查并采取纠正措施以消除导致砂轮卡住的因素。
- f) 不能在工件上重新启动切割操作。让砂轮达到全速后再小心地重新进入切割。如果在工件上重新启动电动工具，砂轮可能会卡住、爬升或反冲。
- g) 为任何超大工件提供支撑可最大程度地降低砂轮卡住和反冲的风险。大工件容易因自身的重量而下陷。必须在工件下方靠近切割线处和砂轮两侧近工件边缘处放置支撑物。

型材切割机附加安全警告

- 操作中，避免撞击圆盘刀或其它粗暴操作。如发生这种情况，请停止操作并检查圆盘刀。
- 操作人员和圆盘刀成一条直线时请勿操作工具。并让其他人员离开工作区域。
- 要注意那些切割下来的碎屑和被切掉的材料。它们可能非常尖锐和灼热。先让切割零件冷却，然后再搬运。
- 使用期间火花偏转板会变热。操作完成后，不要马上触摸或调整火花偏转板。
- 关闭工具电源并等待圆盘刀停止，然后再移动工件或更改设置。
- 关闭电源后，严禁通过按压圆盘的侧面停止圆盘刀。
- 不要使用切削液。这些液体可能会燃烧或引起电击。
- 检查是否正确支撑住了工件。
- 只能使用制造商推荐的圆盘刀。请勿将工具用于其非限定用途；例如，不得使用圆锯片切割树枝或原木。
- 允许的圆盘刀最大速度必须始终等于或大于铭牌上指定的工具空载速度。
- 请勿使用尺寸不符合**技术参数**中介绍的圆盘刀。
- 阅读锯轮制造商提供的操作说明。
- 使用前，确保正确安装和紧固砂轮。
- 让工具在安全位置至少空载运行 30 秒。如果有明显振动或发生任何其他问题，请停止操作并进行检查以确定原因。
- 请勿使用圆盘刀进行侧面研磨。
- 请勿切割混凝土、砖、瓦或陶瓷材料。
- 请勿切割木材、塑料或合成材料。
- 请勿切割铸铁材料。
- 严禁切割镁材料。
- 请勿切割通电材料。
- 在通风良好的区域使用此工具。请勿在易燃液体、气体或粉尘附近使用本工具。切割或电弧马达电刷产生的火花或灼热的碎屑可能引燃易燃材料。
- 在灰尘多的条件下工作时，请定期清洁通风槽。如果需要清洁通风槽，请始终使用软刷；并记住先拔下电源插头。
- 始终将圆盘刀存放在保护良好和干燥的地方，不要让儿童碰到。
- 检查受损部件。进一步使用工具前，损坏的护罩或其他部件应仔细检查，以确定其是否可正确操作并执行其预期功能，即检查运转部件是否有任何安装偏差或卡住、零件是否破损，以及是否有其他可能影响电动工具操作的情况。损坏的护罩或其他部件应由经授权的服务中心进行适当修理或更换。

剩余风险

- 使用这些机器时具有下列风险：
 - 接触旋转部件造成的伤害
 - 切割片破裂造成的伤害。
- 这些危险最常见于：
 - 在操作范围内。
 - 在旋转机器部件范围内。
- 尽管遵守了相关的安全法规并采用了安全装备，某些剩余风险仍然是无法避免的。这些风险包括：
 - 听力损伤。
 - 旋转切割片的未遮盖部件造成的事故风险。
 - 更换锯片时的受伤风险。
 - 打开护罩时夹伤手指的风险。

电气安全

电机只适用一种工作电压。请务必检查电源电压是否与铭牌上的电压一致。



您的 DeWALT 工具依据 IEC62841 标准设置双重绝缘；因此无须接地线。



警告：115 V 装置必须通过故障保险隔离变压器操作，在初级绕组和次级绕组之间使用接地屏蔽。

若电源线损坏，必须交由 DeWALT 维修部门采用专门制备的电线进行更换。

使用延长线

如需使用延长电缆，请使用与本工具的输入功率（见**技术参数**）匹配的经验验 3 芯延长线。最小导体尺寸为 1.5 平方毫米，最大长度为 30 米。

使用电缆卷筒时，请务必拉出所有的电缆。

包装内的物品

包装内的物品包括：

- 1 只 型材切割机
- 1 只 砂轮
- 1 只 六角扳手
- 1 本 说明手册
- 检查工具、部件或附件是否在运输过程中损坏。
- 操作前，请抽空仔细阅读并掌握本手册。

工具上的标记

工具上印有如下列图形：



使用前请阅读使用手册。



请佩戴听力保护器。



请佩戴护目装备。



孔径



旋转方向

日期码位置 (图 A)

日期码 18 印在工具外壳上，其中还包含制造年份。

示例：

2019 XX XX
制造年份

说明 (图 A)



警告：切勿改装电动工具或其任何部件，否则可能会导致损坏或人身伤害。

- | | |
|-----------|------------|
| 1 锁定销 | 5 挡板 |
| 2 火花偏转板螺钉 | 6 台钳 |
| 3 火花偏转板 | 7 8 毫米六角扳手 |
| 4 底座 | 8 曲柄 |

- 9 台钳拨杆
- 10 砂轮
- 11 防护罩
- 12 主轴锁
- 13 锁定触发开关
- 14 锁止杆
- 15 挡板螺栓
- 16 安装孔
- 17 操作手柄
- 18 日期代码
- 19 搬运手柄

设计用途

您的 D28730 型材切割机设计用于切割各种形状的钢材。仅适用于增强型固结研磨产品。钻石或 TCT 锯片不应与本机一起使用。请勿在潮湿环境中或在易燃液体或气体存在的环境中使用本工具。D28730 型材切割机是专业电动工具。

请勿让儿童接触本工具。缺乏经验的操作员需要在监督下使用本工具。

- **儿童和体弱者。**在没有他人监督的情况下，儿童或体弱者不适宜使用本产品。
- 本产品不适合体力、感官或智力不足以及缺乏经验、知识或技能的人员（包括儿童）使用，除非一旁有能为他们的安全负责的监督人员。不得在无人监管的情况下让儿童接触本产品。

组装与调整





警告：为降低严重的人身伤害风险，在进行任何调整或取出/安装附件或配件之前，请关闭工具电源和断开工具电源连接。请确保触发开关处于 OFF（关闭）位置。意外启动可能会导致人身伤害。

切割能力

宽台钳开口和高枢轴点可切割许多大型工件。参照切割能力图表确定使用新砂轮可实现的总体最大切割尺寸。

警告：某些大型的圆形或不规则形状物体如果不能使用台钳安全固定，则可能需要额外的固定方法。

警告：切勿使用此工具切割镁、木材、砖块或混凝土。

工件形状				
90° 切割角度	A = 125 毫米	A = 115 毫米	115 毫米 x 130 毫米	120 毫米
45° 切割角度	A = 115 毫米	A = 98 毫米	95 毫米 x 105 毫米	105 毫米

操作

使用说明

警告：务必遵守安全指示和适用法规。

警告：为降低严重的人身伤害风险，在进行任何调整或取出/安装附件或配件之前，请关闭工具电源和断开工具电源连接。请确保触发开关处于 OFF（关闭）位置。意外启动可能会导致人身伤害。

正确的手持方式 (图 A)

警告：为降低严重人身伤害的风险，请务必使用正确的手持方式，如图所示。

警告：为降低严重的人身伤害风险，请务必紧握工具以防止出现突然的反作用力。

正确的手持位置是一只手握住操作手柄 17。

搬运 (图 A)

向下折叠到位，以便搬运型材切割机。推入锁定销 1 以锁定臂。务必使用搬运手柄 19 以搬运切割机。

解锁 (图 A)

要解锁工具并抬高工具头，请轻轻按下电机臂然后拉出锁定销 1。电机臂会沿枢轴向上转动。

安装 (图 A)

警告：必须在稳定、水平、防滑表面上支撑工具，防止在操作时意外移动。

1. 在工作表面上钻孔，使型材切割机底座对齐。
2. 将两个 M10 螺栓穿过底座中的安装孔 16，然后穿过安装表面中的孔。螺钉的长度大约是安装表面的厚度加 102 毫米。

火花偏转板调整 (图 A)

警告：请勿在操作期间或之后触摸火花偏转板，因为它将变热并可能导致皮肤灼伤。

如需尽可能偏转火花以远离周围的人员和材料，请拧松火花偏转螺钉 2，调整火花偏转板 3，然后重新拧紧螺钉。避免电线组件接触偏转板或火花，否则可能损坏偏转板。

锁定触发开关 (图 A)

如需开启电锯，请将锁止杆 14 推至左侧，然后按下锁定触发开关 13。按下开关时，电锯将运行。切割前，请使锯片加速至全速。如需关闭电锯，请释放触发开关。确保双手和材料远离砂轮，直到砂轮惯性旋转至停止。在抬起锯头之前先等待锯片停止运行。本工具不可锁定为开启状态。

材料夹紧和支撑 (图 B, C)

- 最好的夹紧和切割角度是两个脚架稳固支撑在底座上。
- 垫块 29 比工件 30 稍窄，可增加砂轮利用率 (图 B)。
- 长工件必须用垫块 31 支撑以便与底座顶部持平 (图 C)。切割端 32 应可自由下落以避免砂轮卡住。

台钳操作 (图 A, D)

台钳具备快速移动功能。要松开夹紧的台钳 6，请将曲柄 8 按逆时针方向旋转一到两次以移除夹紧压力。抬起台钳拨杆 9。将曲柄组件向外拉至最远处。台钳可在不使用曲柄的情况下推进到工件上。放下台钳拨杆，然后通过曲柄使用台钳紧固工件。

挡板操作 (图 A, D, E)

警告：在进行任何调整或者取出或安装附件或配件之前，请关闭工具的电源并拔下插头。请确保触发开关处于 OFF（关闭）位置。

挡板 5 的调整方法有两种：更改所需的切割角度以及更改挡板和台钳之间的间距。

更改所需的切割角度

使用随附的 8 毫米六角扳手 7 拧松（请勿移除）两颗挡板螺栓 15。将所需的角度指示线与底座 4 上的插槽线 28 对齐。使用前拧紧两颗挡板螺栓。要实现更精确的直角尺切割，请断开电源连接，拧松两颗挡板螺栓，然后向下推电机臂直到砂轮深入底座。拧紧砂轮放置直角尺，然后根据直角尺调整挡板。使用前拧紧两颗挡板螺栓。进行斜角切割时，台钳 6 可能不会夹紧，具体取决于工件的厚度和斜角角度。进行这些切割时，需要使用其他辅助工具（如弹簧夹、杆夹或 C 形夹）以将工件固定到挡板上。

移除和安装砂轮 (图 F, G)



警告：为降低严重的人身伤害风险，在进行任何调整或移除/安装配件或附件之前，请关闭工具电源和断开工具电源连接。请勿在砂轮旋转时进行任何调整。请勿在型材切割机插入电源时进行任何调整。



警告：处理砂轮时务必戴上手套。



警告：请勿撞击砂轮，也请勿使用已经掉落或经过撞击的砂轮。请勿使用破损，变形或损坏的砂轮。

1. 推入主轴锁 **12** 并手动旋转砂轮 **10**，直到砂轮锁定杆和内部法兰 **20** 上的插槽接合以锁定砂轮。使用 8 毫米六角扳手 **7** 按逆时针方向拧松研磨砂轮中心的螺栓 **21**。螺栓具有右旋螺纹。
2. 移除螺栓 **21**、垫圈 **22**、外部法兰 **23** 和旧砂轮 **10**。
3. 确保法兰表面干净平整。按照以上相反步骤安装新研磨砂轮。
4. 为了安全操作，请牢固地拧紧螺栓 **21**，将砂轮 **10** 牢牢固定在内法兰 **20** 和外法兰 **23** 之间。请勿过度拧紧螺栓 **21**。



警告：更换新研磨砂轮时检查放置型材切割机的工作面。机臂完全放下时，砂轮可能会接触工作面（底座下）的突出部分或任何突出物体。

更精确切割的操作提示

- 让砂轮自行切割。用力过度会导致砂轮变光滑，从而降低切割效率和/或偏转，造成切割不精确。
- 正确调整挡板角度。
- 确保材料平坦放置在底座上。
- 正确夹紧材料，避免移动和振动。

电机电刷检查和更换 (图 H, I)

检查电刷前务必确保已拔除电源插头。应定期检查电刷是否磨损。要检查电刷，请拧松两颗端盖板螺钉 **24** 然后移除端盖板 **25**。在卸下每个电刷 **26** 之前，请先拔下分流线 **27** 端口连接。然后小心地将电刷弹簧从电刷盒中取出并移除电刷。电刷应在电刷盒中自由滑动。如果电刷磨损到如图 I 所示的 8 毫米，则应更换。

在重新安装每个电刷之前，请小心地将弹簧从电刷盒中取出，插入电刷并装回弹簧，以确保弹簧固定住电刷而不会接触到电刷盒。重新连接分流线端口，然后更换端盖和两个螺钉。

维护

DEWALT 电动工具设计精良，可以长期使用，而且只需最少的维护。要持续获得令人满意的工作效果，需要进行合适的工具维护和定期清洁。



警告：为降低严重的人身伤害风险，在进行任何调整或取出/安装附件或配件之前，请关闭工具电源和断开工具电源连接。请确保触发开关处于 OFF (关闭) 位置。意外启动可能会导致人身伤害。



润滑

操作时使用封闭类型的油脂密封滚珠轴承。这些轴承在出厂时具有足够的润滑度，可支撑型材切割机的整个使用寿命。



清洁



警告：一旦看到通风口及其周围积聚了尘屑，请用干燥的空气将灰尘和尘屑从主机外壳内吹出。执行此过程时，需戴上经认可的护目装备和防尘面具。



警告：切勿使用溶剂或其他刺激性化学制品来清洁工具的非金属部件。这些化学物质可能会削弱这些部位使用的材料。请用布蘸温和的肥皂水擦拭。切勿让任何液体渗入工具，切勿让工具的任何部件浸在液体中。

可选配件



警告：除了 DEWALT 提供的附件之外，其他附件都未经此产品兼容性测试，若将此类附件与本工具一起使用将存在安全隐患。为降低人身伤害风险，本产品只可使用 DEWALT 推荐的附件。

请向您的经销商咨询更多关于合适附件的信息。

根据标准 EN12413 针对固结研磨产品的安全要求，请仅使用额定值为 4100 rpm 或更高的高强度 1 型有机固结砂轮。

保护环境



分类回收。由此符号标记的产品和电池不得与普通家庭垃圾一起处理。

产品和电池包含可恢复或回收的材料，从而降低对原材料的需求。请根据当地供给回收电子产品和电池。要获得更多信息，请参看 www.2helpU.com。

金屬切斷機

D28730

恭喜！

感謝您選購 DEWALT 工具。憑藉多年的經驗、完善的產品開發與創新，DEWALT 已成為專業電動工具使用者最可靠的合作伙伴之一。台灣上市之 DEWALT 產品規格、技術資料和訊息，以繁體中文說明為主。

技術資料

		D28730
電壓	伏特 _{交流}	110
輸入功率	瓦特	2300
空載轉速	轉/分	4000
切盤最低圓周速度	m/s	80
切盤直徑	公釐	355
切盤孔徑	公釐	25.4
切盤厚度	公釐	3.0
軸心螺紋尺寸		M10
切盤類型平直式、非隱藏式		
90° 橫切範圍		
圓形	公釐	125
方形	公釐	115 x 115
矩形	公釐	115 x 130
尖角形	公釐	120 x 120
45° 橫切範圍		
圓形	公釐	115
方形	公釐	98 x 98
矩形	公釐	95 x 105
尖角形	公釐	105 x 105
重量	kg	15.5

定義：安全指南

以下定義描述了每一個詞彙的嚴重程度。請閱讀本手冊並注意這些符號。



危險：表示緊急危險狀況，若未能避免，將導致死亡或嚴重傷害。



警告：表示潛在危險情況，若未能避免，可能導致死亡或嚴重傷害。



小心：表示潛在危險情況，若未能避免，可能導致輕微或中度傷害。

注意：表示一種非人身傷害的行為，若未能避免，可能導致財產損失。



表示觸電危險。



表示火災危險。

電動工具一般安全警告



警告：請閱讀本電動工具隨附的所有安全警告、指示、圖示和規格。不遵循下列的所有指示可能會導致觸電、火災及/或嚴重傷害。

請妥善保存所有警告及指示 以備將來查閱

警告中的名詞「電動工具」是指電源驅動（插電）電動工具，或者電池驅動（充電）電動工具。

1) 工作場地安全

- 請保持工作場地清潔明亮。雜亂或黑暗的場地會引發事故。
- 不要在易爆環境，如有易燃液體、氣體或塵埃的環境中操作電動工具。電動工具產生的火花可能會引燃粉塵或煙霧。
- 請等待兒童和旁觀者離開之後才操縱電動工具。分心會導致您疏忽於控制。

2) 電氣安全

- 電動工具插頭必須與插座相符。切勿以任何方式改裝插頭。需接地的電動工具不能使用任何配接器插頭。未經改裝的插頭和相符的插座可以減少觸電危險。
- 避免人體接觸接地表面，如管道、散熱片、爐灶和冰箱。若您的身體接地，會增加觸電危險。
- 不得將電動工具暴露在雨中或潮濕環境中。水進入電動工具會增加觸電危險。
- 請勿濫用電線。請勿使用電線來搬運、拉動電動工具或拔出插頭。讓電線遠離熱、油、銳邊和活動部件。受損或纏繞的電線會增加觸電危險。
- 若要在戶外使用電動工具，請使用適合戶外使用的延長電線。使用適合戶外使用的電線可減少觸電危險。
- 若必須在潮濕場合使用電動工具，請使用接地漏電斷路器 (GFCI)。使用 GFCI 可降低觸電危險。

3) 人身安全

- 保持警覺；在操作電動工具時，請留意所執行的操作並按照一般的常識執行。請勿在疲倦，或受到藥物、酒精或治療的影響下操作電動工具。操作電動工具期間注意力分散會導致嚴重人身傷害。
- 使用個人防護裝置。始終佩戴護目裝置。防護裝置，例如在適當條件下使用的防塵面具、防滑安全鞋、安全帽或聽力保護等裝置可減少人身傷害。
- 避免意外啟動。在連接至電源及/或電池組、抬起或搬運工具之前，請確保開關處於關閉位置。若搬運電動工具時將手指放在開關上，或者在電動工具開關開啟時將插頭插入電源插座，這兩種行為都會引發事故。
- 啟動電動工具之前，請卸下所有的調整鑰匙或扳手。遺留在電動工具旋轉部件上的扳手或鑰匙會導致人身傷害。
- 不要過度伸張雙手。時刻注意腳下與身體的平衡。如此即可在發生意外的情況下更好地控制電動工具。

- f) 適當穿著。請勿穿寬鬆衣服或佩戴飾品。讓頭髮、衣服和手套遠離活動部件。寬鬆衣服、佩飾和長髮可能會捲入手套活動部件。
- g) 若配備用於連接排屑裝置和集塵設備的裝置，請確定正確連接和使用這些裝置。使用集塵設備可減少與粉塵有關的危險。
- h) 請勿因頻繁使用而對工具特別熟悉，讓你變得自滿而忽略工具的安全原則。粗心操作可以在片刻間造成嚴重傷害。

4) 電動工具的使用與注意事項

- a) 請勿超負荷使用電動工具。請根據您的應用使用正確的電動工具。若使用的電動工具正確無誤，該工具能以設計額定值更有效、更安全地執行工作。
- b) 若開關不能開啟或關閉電源，請勿使用該電動工具。若開關無法控制電動工具，則電動工具存在危險，必須予以維修。
- c) 在執行任何調整、更換配件或儲存電動工具之前，必須從電源上拔掉插頭及/或電池組（若可卸下）。這類防護性措施可降低電動工具意外啟動的風險。
- d) 將閒置的電動工具儲存在兒童無法接觸的地方，並且不要讓不熟悉電動工具或對這些使用指示不瞭解的人員操作電動工具。電動工具在未經培訓的使用者手中會發生危險。
- e) 維護電動工具。檢查活動部件是否對準或卡住、破損情況以及是否存在影響電動工具運行的其他情況。若有損毀，必須在使用之前修理電動工具。許多事故都是由於電動工具欠缺維護所導致。
- f) 保持切削工具鋒利和清潔。妥善維護的帶利刃的切削工具不會輕易卡住並可更輕鬆控制。
- g) 在使用電動工具、配件及刀頭等部件時，請遵循上述指示，並將工作條件與要執行的工作考慮在內。不按照設計目的使用電動工具會導致危險。
- h) 手柄和抓握表面都應保持乾燥、清潔及遠離油脂。光滑手柄和抓握表面不便於在意外情況下對工具進行安全處理與控制。

5) 檢修

- a) 本電動工具必須由合格的維修人員並只採用相同的原廠零件來執行檢修。這將確保電動工具的安全性。

切斷機之安全指示

1) 切斷機之安全警告

- a) 保持身體遠離旋轉砂輪的平面，並且勿使旁觀者靠近。防護罩有助於保護操作人員免於受到爆裂砂輪碎片和意外觸及砂輪的危險。
- b) 電動工具僅可使用黏合加強或金剛切割砂輪。就算配件可裝到電動工具上，這並不代表它能確保安全操作。
- c) 配件的額定速度必須至少相等於電動工具上所標示的最大速度。配件以比其額定速度大的速度運行可能會引發爆裂和飛濺。
- d) 砂輪只可用於推薦的用途。例如，不要使用切割砂輪的側面進行打磨。切割砂輪設計用於圓周打磨，施加到砂輪側面的側力可能會使其碎裂。
- e) 始終為所選砂輪選用未損毀、直徑適合的砂輪凸緣。合適的砂輪凸緣可支撐砂輪，從而可以減小砂輪破裂的可能性。

- f) 配件的外徑與厚度必須在電動工具的額定能力範圍內。錯誤尺寸的配件將無法得到充分保護或控制。
- g) 砂輪和凸緣的軸孔尺寸必須適合電動工具的心軸。砂輪和法蘭的軸孔若與電動工具安裝件不相配合導致失穩、過度震動並且可能會引起失控。
- h) 請勿使用受損的砂輪。每次使用之前，請檢查砂輪是否有缺口和裂縫。若電動工具或砂輪跌落，請檢查是否損毀，或安裝未破損的砂輪。檢查並安裝砂輪後，讓自己和旁觀者遠離砂輪的旋轉範圍，並讓電動工具以最大的空載速度運行一分鐘。受損砂輪一般會在此測試過程中碎裂。
- i) 佩戴個人防護裝置。根據適用情況，使用面罩、安全護目鏡或防護眼鏡。適用時，佩戴防塵面具、聽力保護器、手套及能阻擋細小磨料或工件碎片的工作圍裙。護目裝備必須能夠擋住各種操作所產生的飛屑。防塵面具或口罩必須能夠過濾各種操作所產生的顆粒。長期暴露於高強度噪音中可能會使聽力受損。
- j) 讓旁觀者與工作場地保持一定安全距離。任何進入工作場地的人員都必須佩戴個人防護裝置。工件或受損砂輪的碎片可能會飛出並導致緊靠著操作區域的旁觀者受到傷害。
- k) 讓電線遠離旋轉的配件。若控制不當，電線可能會被切斷或纏繞，並可能使您的手或手臂捲入旋轉砂輪中。
- l) 定期清理電動工具的通風口。電動機風扇可將灰塵吸進機殼，過多的金屬粉塵沉積可能會導致電氣危險。
- m) 請勿在易燃材料附近操作電動工具。電動工具放置在易燃表面（如木材）上時，請勿操作。火星可能會點燃這些材料。
- n) 請勿使用需要冷卻液的配件。用水或其他冷卻液可能會導致觸電或觸電致死。

反衝和相關警告

反衝是因卡住或纏繞住的旋轉砂輪產生的突然反作用力。卡住或纏繞會引起旋轉砂輪迅速失速，隨之使失控的切割裝置朝上撞向操作人員。

例如，若砂輪被工件纏繞或卡住，伸入卡住點的砂輪邊緣可能會進入材料表面，從而引起砂輪爬出或反衝。在此條件下，砂輪也可能會破裂。

反衝是由於電動工具使用不當及/或不正確的操作程序或條件而導致，可透過採取下列適當的預防措施而避免：

- a) 保持緊握電動工具，調整身體和手臂位置，以應對反衝。若採取合適的預防措施，操作人員即可以控制向上的反衝力。
- b) 身體不要與旋轉砂輪呈一條直線。如果發生反衝，將會使切割裝置朝上撞向操作人員。
- c) 請勿附接周邊間隙超過 10 公釐或帶有齒形鋸片的鋸條、木臘鋸片和節狀金剛輪。此類鋸片會產生頻繁的反衝和失控。
- d) 請勿「夾」住砂輪或施加過大的壓力。請勿試圖進行過深的切割。給砂輪施加過高的壓力將增加砂輪在切割時的負載，容易纏繞或卡住，而且將增加反衝或砂輪爆裂的可能性。
- e) 砂輪被卡住或無論因任何原因而中斷切割時，關掉電動工具並握住切割裝置不動，直到砂輪完全停止。切勿試圖在砂輪仍然運行時使砂輪脫離切割，否則可能會產生反衝。檢查並採取矯正措施，以消除砂輪卡住的原因。

- f) **切勿在工件上重新啟動切削操作。讓砂輪達到全速後再小心地重新進入切削。**若電動工具在工件中重新啟動，砂輪可能會卡住、爬出或反衝。
- g) **支撐住任何超大工件以最大限度地降低砂輪卡住和反衝的風險。**大型工件由於自身重量而有下陷的傾向。必須在工件靠近切線處及砂輪兩側近工件邊緣處放置支撐物。

切斷機之附加安全警告

- 操作時避免切盤跳動或粗暴操作。如果出現跳動，停止工作，然後檢查切盤。
- 請勿與切盤站在同一直線上操作工具。不可讓其他人員進入工作場地。
- 小心切屑和正在被切割的材料。它們可能銳利且高溫。待切下物料冷卻後再進行處置。
- 使用時火花偏導器將變熱。避免在操作後立即接觸或調整火花偏導器。
- 移動工具或變更設定前要關閉工具並等待切盤停止運轉。
- 關閉後嚴禁嘗試透過按壓切盤側面來阻止切盤運轉。
- 請勿使用切割液。這些液體可能會燃燒或導致觸電。
- 檢查確保工件支撐牢固。
- 只可使用製造商推薦的切盤。請勿將本工具用於非預期用途；例如，不得使用圓鋸鋸片切割樹枝或原木。
- 切盤最大允許速度必須等於或高於銘牌上標注的工具空載速度。
- 請勿使用不符合**技術資料**所標注尺寸的切盤。
- 閱讀切盤製造商提供的操作說明書。
- 確保在使用前砂輪已正確安裝並緊固。
- 讓工具在空載狀態下在安全位置上運行至少 30 秒。若震動明顯或出現其他問題，停止工具進行檢查，找出原因。
- 請勿使用切盤進行側磨。
- 請勿切割混凝土、磚塊、瓷磚或陶瓷材料。
- 請勿切割木質、塑料或合成材料。
- 請勿切割鑄鐵材料。
- 嚴禁切割鎂質材料。
- 請勿切割帶電材料。
- 在通風良好的場地使用本工具。請勿在易燃液體、氣體或粉塵附近操作工具。切割或電弧電動機電刷所產生的火花或熱碎片可能會引燃易燃材料。
- 在布滿灰塵的環境下工作要經常清潔通風槽。若有必要清潔通風槽，請務必使用軟布，並首先拔出切斷機的插頭。
- 務必將切盤妥善包裝並儲存在乾燥且兒童無法接觸的地方。
- 請檢查受損的零件。在進一步使用工具前，應仔細檢查受損的防護罩或其他零件，以確定其是否能正確運作並執行預期功能，即檢查運動的零件是否對齊、運動的零件是否卡住、零件是否有破損、是否已固定以及是否存在可能影響運作的其他狀況。應正確修理或更換受損的防護罩或其他零件。

剩餘風險

- 使用此類機器有以下固有危險：
 - 接觸旋轉部件造成的傷害。
 - 停止切盤轉動導致的傷害。
- 以下這些危險最為常見：
 - 進入運行範圍
 - 進入機器旋轉部件的範圍

- 即使應用有關的安全規定並採用安全設備，仍然還有一些無法避免的剩餘風險。此類風險包括：

- 听力受損。
- 旋轉切盤未遮蔽部件導致的事故危險。
- 更換切盤時的傷害危險。
- 開啟防護裝置時夾傷手指的危險。

電氣安全

電動機只適用一種電壓。請務必檢查電源電壓是否與銘牌一致。



DEWALT 工具根據 IEC62841 進行雙重絕緣，因此不需要使用接地線。



警告：115 伏特裝置必須透過失靈安全隔離變壓器運作，在初級繞組和次級繞組之間使用接地屏蔽。

若電源線損壞，必須使用 DEWALT 維修機構提供的專用電線進行更換。

使用延長電纜

若需要使用延長電纜，請使用適合本工具功率輸入的認證 3 芯延長電纜（請參閱**技術資料**）。導電體的最小橫截面積為 1.5 平方公釐；最大長度為 30 米。

使用電纜捲筒時，每次必須把電纜完全展開。

套裝內的物件

本套裝包括：

- 1 部 金屬切斷機
- 1 個 砂輪
- 1 個 六角扳手
- 1 本 使用手冊

- 檢查工具、部件或配件有否在運送途中損壞。
- 操作前，請抽空徹底地閱讀和掌握本手冊的內容。

工具上的標誌

工具上會附帶下列圖示：



使用前請閱讀使用手冊。



請佩戴聽力保護器。



請佩戴護目鏡。



盤孔直徑



旋轉方向

日期代碼位置 (圖 A)

日期代碼 **18**，包括製造年份，已經印刷在工具外殼上。

範例：

2019 XX XX

製造年份

說明 (圖 A)

警告：切勿改動本電動工具或其任何部件。否則可能導致損壞或人身傷害。

- | | |
|------------|-----------|
| 1 鎖銷 | 11 防護罩 |
| 2 火花偏導器螺絲 | 12 軸心鎖 |
| 3 火花偏導器 | 13 鎖定觸發開關 |
| 4 底座 | 14 鎖定桿 |
| 5 擋板 | 15 擋板螺栓 |
| 6 夾具 | 16 安裝孔 |
| 7 8 公釐六角扳手 | 17 操作手柄 |
| 8 曲柄 | 18 日期代碼 |
| 9 夾具水平支架 | 19 搬運手柄 |
| 10 砂輪 | |

設計用途

D28730 金屬切斷機設計用於切割各種形狀的鋼材。本工具僅設計用於與加強黏合的研磨產品配合使用。不應將金剛或 TCT 鋸片與此裝置配合使用。

請勿在潮濕有水或存有易燃液體或氣體的環境下使用本工具。

D28730 金屬切斷機是專業的電動工具。

不要讓兒童接觸本工具。缺乏經驗的操作人員需要在監督下使用本工具。

- **兒童和體弱者。**兒童或體弱者在沒有他人監督的情況下不適宜使用本工具。
- 體力、感覺或智力不足，以及缺乏經驗、知識或技能的人員（包括兒童）不適合使用本產品，除非一旁有能為他們安全負責的監督人員。請勿讓兒童單獨接觸本工具。

裝配與調整

警告：為了降低造成嚴重人身傷害的風險，在進行任何調整或卸下或安裝附件或配件之前，切記關閉工具並斷開工具電源。請確保觸發開關處於關閉 (OFF) 位置。意外啟動工具可能會造成傷害。

切割能力

本工具有更高的樞軸點、更大的夾具開口，讓它能夠輕易切割許多大型工件。請參閱切割能力圖表，確定新砂輪能切割的工件的最大總尺寸。

小心：某些大型環狀或形狀不規則的物體，則可能會需要動用更多的夾具。

小心：請勿使用本工具來切割鎂質材料、木材、磚塊或混凝土。

工件形狀				
90° 切割角度	A = 125 公釐	A = 115 公釐	115 公釐 x 130 公釐	120 公釐
45° 切割角度	A = 115 公釐	A = 98 公釐	95 公釐 x 105 公釐	105 公釐

操作

使用說明

警告：務必遵守安全指示和適用的規則。

警告：為了降低造成嚴重人身傷害的風險，在進行任何調整或卸下或安裝附件或配件之前，切記關閉工具並斷開工具電源。請確保觸發開關處於關閉 (OFF) 位置。意外啟動工具可能會造成傷害。

正確的雙手放置位置 (圖 A)

警告：為降低遭受嚴重人身傷害的風險，務必如圖示那樣正確放置雙手。

警告：為了減低造成嚴重人身傷害的風險，預期有突然反應時務必握緊。

正確的雙手放置位置是將一隻手放在主手柄 **17** 上。

搬運 (圖 A)

將您的裝置折疊至一個可讓您搬運切斷機的程度。推入鎖銷 **1** 以鎖定電動機移動臂。請務必使用搬運手柄 **19** 搬運切斷機。

解鎖 (圖 A)

要為本工具解鎖並拉高鋸頭，請輕輕按下電動機移動臂並將鎖銷 **1** 往外拉。電動機移動臂將向上轉動。

安裝 (圖 A)

小心：工具必須放置到穩固、平坦和防滑平面上以防止在執行操作時發生意外移動。

1. 在工作表面上鑽孔，使切斷機底座對齊。
2. 將兩顆 M10 螺栓向下插入穿過底座上的安裝孔 **16** 和安裝表面上的孔。螺絲的大致長度為安裝表面的厚度再加上 102 公釐。

調整火花偏導器 (圖 A)

警告：由於火花偏導器會變熱並可能灼傷皮膚，請勿在操作期間或操作後立即接觸火花偏導器。

要將火花偏導至別的地方，避免它濺到周圍人員和材料，請擰鬆火花偏導器螺絲 **2**，調整火花偏導器 **3**，然後再擰緊螺絲。不要讓電源線接觸到火花偏導器或火花，這可能會損壞電源線。

鎖定觸發開關 (圖 A)

若要開啟切斷機，請將鎖定桿 **14** 推向左邊，然後按下鎖定觸發開關 **13**。按下開關時，切斷機將運行。允許鋸片旋轉達到全速後再進行切割。若要關閉切斷機，請鬆開觸發開關。讓手和材料遠離砂輪，直至其停止運轉。在抬起鋸頭之前，請等候鋸片停止。未提供將開關鎖定在開啟狀態的裝置。

夾緊並支撐材料 (圖 B、C)

- 用兩個支腳抵住工具底座，即可最好支撐工件進行斜角切割。
- 可使用比工件 **30** 稍窄的墊塊 **29**，以增加砂輪利用率 (圖 B)。
- 長工件必須由墊塊 **31** 支撐，好讓它能夠與底座的頂部呈水平線 (圖 C)。工件的切斷端 **32** 必須能夠自由向下掉落，避免導致砂輪卡住。

夾具操作 (圖 A、D)

夾具擁有一個快速移動功能。要鬆開緊夾的夾具 **6**，請逆時針轉動曲柄 **8** 一圈至四圈，去除夾緊壓力。將夾具水平支架 **9** 提起。拉出曲柄裝配，直至所需位置。無需使用曲柄即可將夾具推入工件中。降下夾具水平支架，再利用曲柄將夾具擰緊到位。

擋板操作 (圖 A、D、E)

警告：調整、卸下或安裝附件或配件之前，必須先關閉工具的電源並拔下插頭。請確保觸發開關處於關閉 (OFF) 位置。

擋板 **5** 調整有兩種方法：改變所需切割角度，以及改變擋板和夾具之間的距離。

改變所需切割角度

利用所提供的 8 公釐六角扳手 **7** 鬆開兩個擋板螺栓 **15**（但請不要拆下）。將所需的角度指示線與底座 **4** 上的槽線 **28** 對齊。使用前，請牢固擰緊這兩個擋板螺栓。若要進行更加精確的方形切割，請關掉電源，擰鬆兩個擋板螺栓，並將移動臂往下推，直至砂輪碰到底座為止。將一塊方形緊貼砂輪，並根據這個方形調整擋板。使用前，請牢固擰緊這兩個擋板螺栓。根據不同工件的厚度和斜口切角度而論，夾具 **6** 有可能在您進行斜口切時無法牢固夾緊您的工件。因此，在進行這類切割時，可能會需要利用一些其他的輔助工具（如彈簧、條或 C 型萬力夾）來將工件固定到擋板上。

拆下與安裝砂輪 (圖 F 和 G)

警告：為了降低造成嚴重人身傷害的風險，在進行任何調整或卸下或安裝附件或配件之前，切記關閉工具並斷開工具電源。請勿在砂輪還在轉動的當兒作出任何調整。請勿在切斷機電源還接通的時候作出任何調整。

警告：接觸砂輪時請務必佩戴手套。

警告：請勿撞擊砂輪以及使用會掉落或遭受過撞擊的砂輪。請勿使用已破損、變形或損壞的切割砂輪。

- 將軸心鎖 **12** 推入，用手轉動砂輪 **10**，直至砂輪的鎖桿與內法蘭 **20** 接合，鎖定砂輪。利用 8 公釐六角扳手 **7**，將砂輪切片中間的螺栓 **21** 逆時針轉動以將其擰鬆。此螺栓採用右旋螺紋。
- 拆下螺栓 **21**、墊圈 **22**、外法蘭 **23** 以及舊砂輪 **10**。
- 確保法蘭表面乾淨、平滑。以相反順序安裝新的砂輪切片。
- 為確保安全操作，請牢固地擰緊螺栓 **21**，將砂輪 **10** 牢牢固定在內法蘭 **20** 和外法蘭 **23** 之間。不要將螺栓 **21** 擰得過緊。

警告：進行砂輪切片更換時，請檢查切斷機所停放的工作表面。當移動臂被完全降下時，砂輪切片有可能會接觸到/切入任何處於底座下、工作表面之上的物件或結構！

更精確的切割操作提示

- 讓砂輪自動切割。過度使用蠻力將拋光砂輪的表面，進而降低其切割效率並/或導致砂輪彎曲，造成切割不準確。
- 適當調整擋板角度。
- 確保材料平躺在底座上。
- 適當夾緊材料，以避免移動和震動。

檢查和更換電動機電刷 (圖 H、I)

檢查電刷前，請確定已拔出工具插頭。應定期檢查電刷是否出現磨損。要檢查電刷，請擰鬆兩個端蓋螺絲 **24**，然後拆下端蓋 **25**。

要卸下電刷 **26**，首先拔下分流線 **27** 終端連接，然後小心地將電刷彈簧從電刷盒中取出並取下電刷。電刷應該能夠在電刷盒中自由滑動。如果電刷如圖 I 所示，已磨損至 8 公釐，則應對其進行更換。如要重新安裝電刷，請小心地將彈簧從電刷盒中取出，插入電刷並裝回彈簧，確保彈簧按住電刷而非接觸電刷盒。重新連接分流線終端，然後放回端蓋和兩個螺絲。

維護

DEWALT 電動工具採用卓越的設計，能夠長時間使用，並且只需最少的維護。若要持續獲得滿意的操作效果，需進行正確的工具維護和定期的清潔。

警告：為了降低造成嚴重人身傷害的風險，在進行任何調整或卸下或安裝附件或配件之前，切記關閉工具並斷開工具電源。請確保觸發開關處於關閉 (OFF) 位置。意外啟動工具可能會造成傷害。



潤滑

全機器使用了潤滑脂密封球面滾子軸承。這些滾子軸承在原廠已經過足夠潤滑，可以在切斷機的整個工作壽命期間持續使用。



清潔

警告：一旦通風口及其周圍積聚可見的粉塵，請立即使用乾燥的壓縮空氣吹掉主機外殼內的粉塵和灰塵。執行此步驟時，請佩戴經認可的護目裝備和防塵面罩。

警告：切勿使用溶劑或其他刺激性化學品來清潔工具的非金屬部件。這些化學品可能會削弱部件中使用的材料。只能使用抹布蘸中性肥皂水進行清潔。不要讓任何液體進入工具；不要讓工具的任何部分浸入液體中。

選購配件

警告：由於非 DEWALT 所提供的配件未在本產品上進行過使用測試，在本產品上使用這些附件可能發生危險。為降低進一步傷害危險，在本產品上只應使用 DEWALT 所推薦的配件。

如需進一步瞭解適用配件的相關資訊，請洽詢當地代理商。僅可根據黏合研磨產品的安全要求 EN12413 使用有機黏合的高強度 1 號砂輪，額定速度必須為 4100 轉/分或以上。

保護環境



分開收集。帶有此標誌的產品和電池必須與一般家庭廢物分開處置。

產品和電池包含可重複使用或回收的材料，可降低對原材料的需求。請根據當地法規回收電氣產品和電池。更多資訊，請造訪 www.2helpu.com。

進口商：新加坡商百得電動工具(股)公司台灣分公司

地址：台北市士林區德行西路 33 號 2 樓

電話：02-28341741

總經銷商：永安實業股份有限公司

地址：新北市三重區新北大道二段 137 號

電話：02-2999463

고속절단기

D28730

축하합니다!

DeWALT 공구를 선택해 주셔서 감사합니다. 제품 개발과 혁신을 통한 다년간의 경험은 DeWALT를 전문 전동 공구 사용자들이 가장 믿을 수 있는 제품으로 만들어 왔습니다.

기술 데이터

		D28730
전압	V_{AC}	220-240
소비전력	W	2300
무부하 속도	분 ⁻¹	4000
절삭 디스크 최저 주속	m/s	80
디스크 직경	mm	355
디스크 보어	mm	25.4
디스크 본체 두께	mm	3.0
스핀들 스테드 크기		M10
절삭 디스크 유형 스트레이트		
90°에서의 교차 절삭 능력		
원형	mm	125
정사각형	mm	115 x 115
직사각형	mm	115 x 130
모서리	mm	120 x 120
45°에서의 교차 절삭 능력		
원형	mm	115
정사각형	mm	98 x 98
직사각형	mm	95 x 105
모서리	mm	105 x 105
무게	kg	15.5

정의: 안전 지침

다음 정의는 각 경고 문구의 심각도를 설명합니다. 사용 설명서를 읽고 다음 기호들에 유의하십시오.



위험: 절박한 위험 상태를 나타내며, 방지하지 않으면 **사망** 또는 **심각한 부상을 초래합니다.**



경고: 잠재적 위험 상태를 나타내며, 방지하지 않으면 **사망** 또는 **심각한 부상을 초래할 수 있습니다.**



주의: 잠재적으로 위험한 상태를 나타내며, 방지하지 않으면 **경미하거나 가벼운 부상을 초래할 수 있습니다.**

참고: 신체 부상을 초래하지 않는 행위를 나타내며, 방지하지 않으면 **재산상의 손해가 발생할 수 있습니다.**



감전 위험을 나타냅니다.



화재 위험을 나타냅니다.

전동 공구에 관한 일반 안전 경고



경고: 이 전동 공구와 함께 제공되는 모든 안전 경고와 **지시사항, 설명 및 사양을 읽으십시오.** 아래 설명한 모든 지시 사항을 따르지 않으면 감전, 화재 및/또는 심각한 부상을 초래할 수 있습니다.

항후 참고할 수 있도록 본 사용자 설명서를 잘 보관해두시기 바랍니다

경고에서 사용된 "전동 공구"라는 용어는 주 공급 전원에 의해 전기가 공급되는(유선) 전동 공구 또는 충전식(무선) 전동 공구를 의미합니다.

1) 작업장 안전

- 작업장을 항상 청결하고 밝게 유지하십시오.** 혼잡하거나 어두운 작업장에서는 사고가 발생하기 쉽습니다.
- 가연성 액체, 가스 또는 먼지 등이 있는 폭발성 대기에서 전동 공구를 사용하지 마십시오.** 전동 공구에서 먼지나 가스를 발화시킬 수 있는 불꽃이 될 수 있습니다.
- 전동 공구로 작업하는 동안에는 어린이와 주변 사람들이 작업 영역에 가까이 들어오지 못하도록 하십시오.** 주변이 산만해져 통제력을 잃을 수 있습니다.

2) 전기 안전

- 전동공구의 플러그는 콘센트와 형식이 일치해야 하며, 플러그를 어떤 형태로든 개조하지 마십시오.** 또한 **접지된 전동공구에 다른 어댑터 플러그를 사용하지 마십시오.** 개조되지 않은 플러그 및 형식이 일치하는 콘센트를 사용하면 감전 위험이 줄어듭니다.
- 파이프 판, 라디에이터, 랜지, 냉장고 등의 접지 표면에 물이 닿지 않도록 하십시오.** 몸에 닿을 경우 감전이 될 위험이 높아집니다.
- 전동 공구를 비 또는 습한 환경에 노출하지 않도록 주의하십시오.** 전동 공구에 물이 들어가면 감전 위험이 높아집니다.
- 코드를 함부로 다루지 마십시오.** 코드를 사용하여 전동공구를 운반하거나, 코드를 과도하게 잡아당겨서 플러그를 뽑지 않도록 주의 하십시오. 전열코드가 열기 또는 오일과 접촉되는 것을 피하고, 날카로운 모서리 또는 기기의 기동 부위에 닿지 않도록 주의 하십시오. 코드가 손상되거나 얽혀 있으면 감전 위험이 높아집니다.
- 전동 공구를 실외에서 사용할 때는 실외 사용에 적합한 연장 코드를 사용하십시오.** 실외 사용에 적합한 코드를 사용하면 감전 위험이 줄어듭니다.
- 어쩔 수 없이 습한 장소에서 전동 공구를 사용해야 하는 경우에는 누전차단기(GFCI)로 보호된 전원 공급 장치를 사용하십시오.** 누전차단기(GFCI)를 사용하면 감전 위험이 줄어듭니다.

3) 신체 안전 사항

- 전동 공구로 작업할 때는 방심하지 말고 작업에 주의하면서 상식에 따르십시오.** 피곤한 상태이거나 약물, 술, 치료제를 복용한 상태에서는 전동 공구를 사용하지 마십시오. 전동 공구를 사용하다 잠깐만 한 눈을 팔아도 심각한 부상을 당할 수 있습니다.

- b) **신체 보호 장비를 착용하십시오. 항상 보안경을 착용하십시오.** 적절한 상황에서 방진 마스크, 미끄럼 방지 안전화, 안전모 또는 청력 보호 기구 등의 보호 장비를 사용하면 신체 부상 위험이 줄어듭니다.
- c) **의도하지 않은 장비 가동 방지. 전원 및/또는 배터리 팩에 연결한 상태로 공구를 선택 또는 운반할 때는 사전에 스위치가 꺼짐 위치에 있는지 반드시 확인하십시오.** 스위치가 켜짐 위치에 있는 상태에서 스위치가 손가락이 닿은 상태로 전동 공구를 운반하거나 전동 공구에 전원을 공급하면 사고가 발생합니다.
- d) **전동 공구를 켜기 전에 모든 조정 키 또는 렌치를 제거하십시오.** 전동 공구의 회전 부품에 렌치나 키가 부착되어 있으면 부상을 당할 수 있습니다.
- e) **무리하게 팔을 뻗지 마십시오. 항상 올바른 자세로 서서 균형을 유지하십시오.** 안정된 자세로 작업을 할 경우 전동 공구를 안전하게 사용할 수 있습니다.
- f) **적절한 작업복을 착용합니다. 헐렁한 옷이나 장신구를 착용하지 마십시오. 머리카락, 옷 및 장갑이 움직이는 부품에 닿지 않도록 유의하십시오.** 헐렁한 옷, 장신구 또는 긴 머리카락이 움직이는 부품에 걸릴 수 있습니다.
- g) **먼지 배출 및 집진 시설 연결을 위한 장치가 제공된 경우, 이를 장치가 연결되어 적절히 사용되고 있는지 반드시 확인하십시오.** 집진 장치를 사용하면 먼지와 관련된 위험을 줄일 수 있습니다.
- h) **장치를 자주 사용함으로써 생긴 익숙함으로 인해 현실에 안주하거나 공구 안전 원칙을 무시하지 않도록 하십시오.** 부주의한 작동은 순식간에 심각한 부상을 야기할 수 있습니다.

4) 전동 공구 사용 및 관리

- a) **전동 공구에 무리한 힘을 가하지 마십시오. 해당 용도에 맞는 올바른 전동 공구를 사용하십시오.** 올바른 전동 공구를 사용해 설계된 속도로 작업을 더욱 안전하고 정확하게 수행할 수 있습니다.
- b) **켜지지 않거나 꺼지지 않는 경우 전동 공구를 사용하지 마십시오.** 스위치가 제어되지 않는 전동 공구는 위험하므로 수리해야 합니다.
- c) **전동 공구를 조정하거나 액세서리를 변경하거나 보관하기 전에 전동 공구에서 분리되는 경우 전원 및/또는 배터리 팩에서 플러그를 분리하십시오.** 이러한 예방적 안전 조치를 따라야 전동 공구가 갑자기 작동할 위험이 줄어듭니다.
- d) **사용하지 않는 전동 공구는 어린이의 손이 닿지 않는 곳에 보관하고, 전동 공구나 본 지시 사항에 익숙하지 않은 사람이 전동 공구를 절대 사용하지 못하게 하십시오.** 전동공구에 대한 훈련을 받지 않은 사용자가 전동공구를 함부로 다룰 경우 예기치 않은 사고를 초래 할 수 있습니다.
- e) **전동 공구 유지 보수. 움직이는 부품의 잘못된 정렬이나 바인딩, 부품 파손 및 기타 전동 공구의 작동에 영향을 미칠 수 있는 기타 모든 상태를 확인하십시오.** 손상된 부분이 있는 경우 사용하기 전에 전동 공구를 수리하십시오. 많은 사고는 전동 공구를 제대로 유지 보수하지 않아 발생합니다.
- f) **절삭 공구를 예리하고 깨끗한 상태로 유지하십시오.** 절삭 가장자리를 예리하게 잘 유지하면 절삭기를 사용할 때 바인딩이 적고 다루기가 용이합니다.

- g) **작업 환경과 수행할 작업을 고려하여, 본 지시 사항에 따라 전동 공구, 액세서리 및 톨 비트 등을 사용하십시오.** 본 사용 설명서의 내용과 다른 용도로 전동 공구를 사용하면 위험한 상황이 발생할 수 있습니다.
- h) **핸들과 잡는 표면은 건조하고 깨끗한 상태를 유지하고 오일/기름이 묻지 않도록 하십시오.** 미끄러운 핸들과 잡는 면은 예기치 못한 상황에서 안전한 취급과 공구 관리를 보장하지 않습니다.

5) 정비

- a) **자격을 갖춘 기술자가 동일 교체 부품을 사용하여 정비 작업을 수행해야 합니다.** 그래야 전동 공구의 안전이 보장됩니다.

절단기에 대한 안전 지침

1) 절단기 안전 경고

- a) **사용자와 주변인은 회전하는 휠 작업대로부터 멀리 위치를 잡으십시오.** 가드는 작업자가 휠과 실수로 닿거나 손상된 휠 파편으로부터 작업자를 보호해 줍니다.
- b) **전동 공구에는 유기 강화 또는 다이아몬드 절단 휠만 사용하십시오.** 전동 공구에 부착할 수 있다고 해서 반드시 안전하게 조작할 수 있는 것은 아닙니다.
- c) **액세서리의 정격 속도는 최소한 전동 공구에 표기되어 있는 최대 속도와 같아야 합니다.** 정격 속도보다 빠르게 작동하는 액세서리는 파손되어 튀겨 나갈 수 있습니다.
- d) **휠은 권장 용도로만 사용해야 합니다. 예: 절단 휠의 측면으로 연마 작업을 하지 마십시오.** 연삭 절단 휠은 원주 연삭용이며 휠의 측면에서 힘을 주면 산산이 부서질 수 있습니다.
- e) **항상 선택된 휠에 맞는 직경이 정확한 손상되지 않은 휠 만조를 사용하십시오.** 적합한 휠 만조는 휠을 지지해 휠 파손 가능성을 줄여줍니다.
- f) **액세서리의 외경 및 두께는 사용하는 전동 공구의 용량 등급 이내이어야 합니다.** 잘못된 규격의 액세서리는 제대로 보호하거나 제어할 수 없습니다.
- g) **휠 및 만조의 주축 크기는 전동 공구의 스피ndl에 꼭 맞아야 합니다.** 주축 구멍이 전동 공구에 장착할 하드웨어와 맞지 않는 휠과 만조는 균형을 잃어 과도하게 진동하며 통제할 수 없게 됩니다.
- h) **손상된 휠은 사용하지 마십시오. 사용 전에 휠이 깎이거나 갈라지지 않았는지 검사하십시오. 전동 공구나 휠을 떨어뜨린 경우에는 손상된 부분이 없는지 검사하고 손상된 부분이 있을 경우 손상되지 않은 휠을 설치하십시오. 휠을 검사 및 설치한 뒤 회전하는 휠 작업대에서 멀리 거리를 유지하고 전동 공구를 1분 간 최대 무부하 속도로 작동시키십시오. 휠이 손상된 경우 보통 이 테스트 중에 떨어져 나갑니다.**
- i) **신체 보호 장비를 착용하십시오. 용도에 따라 안면보호구, 안전 고글 또는 보안경을 이용하십시오. 필요에 따라 작은 연삭 또는 작업을 파편을 막을 수 있는 방진 마스크, 청력보호구, 장갑 및 작업용 앞치마를 착용하십시오.** 보안경은 다양한 작업으로 인해 생성되는 비산 파편들을 차단할 수 있어야 합니다. 마스크나 방독 마스크는 작업으로 인해 생성되는 먼지를 거를 수 있어야 합니다. 높은 소음에 오랫동안 노출되면 청력이 손상될 수 있습니다.

- j) 주변 사람들이 작업 영역으로부터 안전 거리를 유지하게 하십시오. 작업 영역에 들어오는 사람들은 모두 신체 보호 장구를 착용해야 합니다. 작업물 또는 손상된 휠 파편이 작업 중인 곳을 벗어나 멀리 날아가 부상을 입힐 수 있습니다.
- k) 코드는 회전하는 액세서리에 닿지 않게 하십시오. 통제를 하지 못할 경우 코드가 잘리거나 감겨 작업자의 손이나 팔이 회전하는 휠에 끌려 들어갈 수 있습니다.
- l) 전동 공구의 통공구를 주기적으로 청소하십시오. 모터의 팬은 하우징 내부로 먼지를 흡입하는데 금속 가루가 너무 많이 쌓이면 전기 장치가 고장 날 수 있습니다.
- m) 가연성 물질 근처에서 전동 공구를 작동시키지 마십시오. 나무 등 가연성 표면 위에서는 전동 공구를 작동시키지 마십시오. 스파크로 인해 점화가 될 수 있습니다.
- n) 냉각용 액체가 필요한 액세서리는 사용하지 마십시오. 물이나 기타 액체 냉매를 이용하면 감전사 또는 감전될 수 있습니다.

반동 및 관련 경고

반동이란 회전하는 휠이 꼭 끼거나 장애물에 걸려 생기는 갑작스런 반작용을 의미합니다. 장애물에 끼거나 걸리면 회전하는 휠이 급속히 감속되어 통제력을 잃은 절단기가 작업자를 향하여 위쪽으로 밀립니다. 예를 들어, 연삭 휠이 작업물에 걸리거나 낚 경우 낚 지점으로 들어가는 휠 가장자리가 작업물의 표면을 파고 들어 휠이 튀어 나올 수 있습니다. 그러한 상황에서는 연마 휠도 파손될 수 있습니다.

반동은 전동 공구를 잘못 사용하거나 잘못된 조작 절차 또는 조건으로 인해 발생할 수 있으며 아래와 같은 올바른 예방 조치를 취해야 막을 수 있습니다.

- a) 전동 공구를 꼭 쥐고 반발력에 저항할 수 있는 자세를 유지하십시오. 작업자가 적절한 예방 조치를 취하면 상당 반동력을 제어할 수 있습니다.
- b) 회전하는 휠의 일직선 상에 있지 마십시오. 반동으로 인해 절단기가 작업자 위쪽으로 튕 수 있습니다.
- c) 전기톱 목공용 날, 10 mm 이상 주변부와 틈이 있는 분할된 다이아몬드 휠 또는 틈이 있는 톱날을 부착하지 마십시오. 이러한 톱날은 반동이 생기거나 통제력을 잃게 되는 경우가 있습니다. 이러한 톱날은 반동이 생기거나 통제력을 잃게 되는 경우가 있습니다.
- d) 휠이 "걸리게" 하거나 과도한 압력을 주지 마십시오. 지나치게 깊은 절단을 시도하지 마십시오. 휠에 과도한 압력을 가하면 부하가 증가해 휠이 뒤틀리거나 절단 부위에 고착되거나 반동 또는 휠이 파손될 수 있습니다.
- e) 어떤 이유로든 휠이 고착되거나 절단이 되지 않을 때는 전동 공구의 전원을 끄고 휠이 완전히 멈출 때까지 절단기를 움직이지 않게 하십시오. 휠이 움직이는 동안에는 절단 부위에서 휠을 떼려 하지 마십시오. 그렇지 않으면 반동이 생길 수 있습니다. 검사를 받아서 휠 고착 원인을 제거하기 위한 조치를 취하십시오.
- f) 작업물에서 절단 작업을 다시 시작하지 마십시오. 휠이 최대 속도에 도달하도록 한 뒤 조심해서 절단을 다시 시작하십시오. 작업물에서 전동 공구를 다시 가동하면 휠이 고착되거나 작업물을 타고 휩 올라가거나 튕 수 있습니다.
- g) 너무 큰 작업물은 휠이 끼여 반동이 생길 위험을 최소화할 수 있도록 반침대로 받쳐 주십시오. 작업물이 너무 크면 무게로 인해 처지곤 합니다. 지지대는 가공물 아래 절단선 가까이, 그리고 휠 양쪽의 가공물 가장자리 가까이에 배치해야 합니다.

절단기에 대한 추가 안전 경고

- 작동 중일 때에는 절삭 디스크를 툽기거나 거칠게 다루지 마십시오. 이런 일이 생길 경우 공구를 멈추고 절삭 디스크를 검사하십시오.
- 절삭 디스크와 일직선 방향에 선 채로 공구를 조작하지 마십시오. 다른 사람들은 작업 공간에서 멀리 떨어져 있게 하십시오.
- 절삭으로 인한 반스리기 및 절삭물 파편을 조심하십시오. 날카롭고 뜨거울 수 있습니다. 절삭된 부분이 식을 때까지 만지지 마십시오.
- 사용 중에 불꽃 반사대가 뜨거워집니다. 작업 후 바로 뒤에 불꽃 반사대를 만지거나 조정하지 마십시오.
- 작업물을 옮기거나 설정을 바꾸기 전에 공구의 스위치를 끄고 절삭 디스크가 멈출 때까지 기다리십시오.
- 스위치를 끈 뒤, 절대 디스크 가장자리를 눌러 절삭 디스크를 멈추려 하지 마십시오.
- 절삭제를 사용하지 마십시오. 절삭제는 발화나 감전의 원인이 될 수 있습니다.
- 작업물을 제대로 받쳐 놓았는지 확인하십시오.
- 제조업체에서 권장하는 절삭 디스크만 사용하십시오. 의도하지 않은 용도, 예를 들어, 나무가지 또는 통나무를 절단하는 용도로 회전 톱날을 사용하지 마십시오.
- 절삭 디스크의 최대 허용 속도는 항상 공구의 명판에 명시되어 있는 무부하 속도 이상이어야 합니다.
- 기술 데이터에 명시되어 있는 규격과 다른 절삭 디스크를 사용하지 마십시오.
- 휠 제조업체가 공급한 작동 지침을 읽어 보십시오.
- 사용하기 전에 연마용 휠이 올바르게 장착되어 있고 조여져 있는지 확인하십시오.
- 안전한 위치에서 최소 30 초 동안 무부하로 공구를 가동시키십시오. 상당한 진동이나 다른 결함이 발생하면 공구를 멈추고 검사를 통해 원인을 파악하십시오.
- 측면 연마용으로 절삭 디스크를 사용하지 마십시오.
- 콘크리트, 벽돌, 타일 또는 세라믹 소재는 절단하지 마십시오.
- 목재, 플라스틱 또는 합성소재는 절단하지 마십시오.
- 주철 소재는 절단하지 마십시오.
- 마그네슘 소재는 절대 절단하지 마십시오.
- 전기가 흐르는 소재는 절단하지 마십시오.
- 이 공구는 환기가 잘 되는 장소에서 사용하십시오. 가연성 액체, 가스 또는 먼지가 있는 장소에서 이 공구를 작동하지 마십시오. 절삭 또는 후 모터 브러시에서 튀는 불꽃이나 뜨거운 파편으로 인해 가연성 물질에 불이 붙을 수 있습니다.
- 먼지가 많은 환경에서 작업할 때는 환기 구멍을 정기적으로 청소해 주십시오. 환기 구멍을 청소해야 할 경우 항상 부드러운 브러시를 사용하고 먼저 공구의 플러그를 뽑으십시오.
- 절삭 디스크는 항상 보호가 잘 되어 있고 어린이들의 손이 닿지 않는 건조한 장소에 보관하십시오.
- 손상된 부품을 확인하십시오. 추가로 공구를 사용하기 전에, 가드 또는 기타 부품을 주의깊게 점검하여 올바르게 작동하여 의도한 기능을 수행하고 있는지 판단하십시오. 움직이는 부품의 정렬, 움직이는 부품의 바인딩, 부품의 파손, 장착 및 작동에 영향을 미칠 수 있는 기타 모든 상태를 점검하십시오. 손상된 가드 또는 기타 부품은 올바르게 수리하거나 교체해야 합니다.

기타 발생 가능한 위험

- 이러한 기계 사용 시에는 항상 다음과 같은 위험이 내재되어 있습니다.
 - 돌아가는 부품을 만짐으로 인해 발생하는 부상.
 - 절삭 디스크 파손으로 인한 부상.
- 이러한 위험은 다음과 같은 곳에서 뚜렷하게 나타납니다.
 - 작업 범위 이내
 - 회전하는 장비 부품의 작동 범위 이내
- 관련된 안전 규정을 준수하고 안전 장치를 사용한다고 해도 특정한 위험은 피할 수 없습니다. 이러한 위험은 다음과 같습니다.
 - 청력 손상.
 - 회전하는 절삭 디스크의 부품들이 덮여 있지 않은 데 따른 사고 위험.
 - 디스크 교체 시의 부상 위험.
 - 가드를 열 때 손가락이 눌리는 위험.



보어 직경



회전 방향 선택

날짜 코드 위치(그림 A)

날짜 코드 **18**에는, 제조년도가 포함되어 이 제조년도는 케이스에 인쇄되어 있습니다.

예:

2019 XX XX

제조년도

설명(그림 A)



경고: 전동 공구 또는 전동 공구의 어떤 부품도 절대 개조하지 마십시오. 제품이 파손되거나 신체 부상을 당할 수 있습니다.

- | | |
|-------------|----------------|
| 1 잠금 핀 | 11 가드 |
| 2 불꽃 반사대 나사 | 12 스프링 잠금 장치 |
| 3 불꽃 반사대 | 13 락오프 트리거 스위치 |
| 4 베이스 | 14 락오프 레버 |
| 5 펜스 | 15 펜스 볼트 |
| 6 바이스 | 16 장착 구멍 |
| 7 8 mm 육각 키 | 17 작동 핸들 |
| 8 크랭크 | 18 날짜 코드 |
| 9 바이스 레버 | 19 운반용 핸들 |
| 10 휠 | |

전기 안전

전기 모터는 한 가지 전압에만 맞추어 설계되었습니다. 전원이 전동기 라벨에 기재된 전압과 일치하는지 항상 확인하십시오.



DEWALT 공구는 IEC62841에 따라 이중 절연되어 있으므로 접지선이 필요 없습니다.



경고: 115 V 기기는 1차 권선과 2차 권선 사이에 접지판이 있는 페일 세이프 절연 변압기를 통해 작동되어야 합니다.

전원 코드가 손상된 경우에는 DEWALT 서비스 센터를 통해 특수 제작된 코드로 교체해야만 합니다.

연장 케이블 이용

연장 케이블이 필요할 경우 이 공구의 소비전력에 맞는 승인된 3 코어 연장 케이블을 사용하십시오(**기술 데이터** 참조). 최소 도체 크기는 1.5 mm², 최대 길이는 30 m입니다.

케이블 릴을 사용할 때는 항상 케이블을 완전히 푸십시오.

포장 내용물

포장에는 다음 내용물이 들어 있습니다.

- 1 고속절단기
- 1 연삭 휠
- 1 육각 키
- 1 사용 설명서
- 운반 중에 발생할 수 있는 공구, 부품 또는 액세서리의 손상 여부를 확인하십시오.
- 작동 전에 시간을 내어 본 사용 설명서를 읽고 숙지하십시오.

공구에 표시된 마크

공구에는 다음과 같은 그림이 있습니다.



사용 전에 사용 설명서의 내용을 숙지하십시오.



귀 보호 장구를 착용하십시오.



보안경을 착용하십시오.

용도

D28730 고속절단기는 다양한 형태의 철물 절단용으로 설계되었습니다. 강화 유리 연마제와만 함께 사용하도록 고안되었습니다. 다이아몬드 또는 TCT 날은 이 기기와 함께 사용하지 말아주세요.

습한 환경이나 가연성 액체 또는 가스가 있는 장소에서 사용하지 마십시오.

D28730 고속절단기는 전문가용 전동 공구입니다.

어린이가 이 공구를 만지지 **않도록 하십시오**. 경험이 없는 작업자가 이 공구를 사용할 때는 감독자의 지도가 필요합니다.

- **어린이 및 노약자.** 본 제품은 어린이나 노약자가 사용하도록 설계되지 않았습니다. 이러한 사람이 사용할 때는 감독이 필요합니다.
- 본 제품은 안전 책임을 맡고 있는 사람이 감독을 하고 있지 않는 한 경험, 지식 또는 기술이 부족하고 신체적, 감각적 또는 정신적 능력이 미약한 사람(어린이 포함)이 사용하도록 고안된 것이 아닙니다. 이 제품과 함께 어린이만 혼자 두어서는 안됩니다.

조립 및 조정







경고: 심각한 신체 부상의 위험을 줄이려면 부착물 또는 액세서리를 조정하거나 제거/설치하기 전에 공구를 끄고 전원에서 공구 플러그를 빼십시오. 트리거 스위치가 껐진 위치에 있는지 반드시 확인하십시오. 공구가 갑자기 작동하여 부상을 당할 수 있습니다.

절삭력

바이스 입구의 폭이 넓고 회전 중심점이 높으면 커다란 작업물을 절삭하기가 보다 수월해집니다. 절삭력 차트를 참고하여 새 휠로 자를 수 있는 최대 크기를 확인하십시오.

! **주의:** 크기가 크거나 원형 또는 불규칙한 모양의 작업물이 바이스에 잘 고정되지 않는 경우 추가적인 고정 수단이 필요합니다.

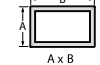
! **주의:** 이 공구로 마그네슘, 나무, 벽돌 또는 콘크리트를 절삭하지 마십시오.

작업물 모양				
90° 절삭 각도	A = 125 mm	A = 115 mm	115 mm x 130 mm	120 mm
45° 절삭 각도	A = 115 mm	A = 98 mm	95 mm x 105 mm	105 mm

조작

사용 지침

! **경고:** 안전 지시 사항과 해당 규정을 항상 준수하십시오.

! **경고:** 심각한 신체 부상의 위험을 줄이려면 부착물 또는 액세서리를 조정하거나 제거/설치하기 전에 공구를 끄고 전원에서 공구 플러그를 빼십시오. 트리거 스위치가 꺼진 위치에 있는지 반드시 확인하십시오. 공구가 갑자기 작동하여 부상을 당할 수 있습니다.

올바른 손의 위치(그림 A)

! **경고:** 심각한 신체 부상의 위험을 줄이려면 항상 그림과 같이 올바르게 손을 위치하십시오.

! **경고:** 심각한 신체 부상의 위험을 줄이려면, 항상 급작스러운 반동을 예상하고 단단히 잡으십시오.

올바른 손의 위치가 되려면 한 손을 작동 핸들 **17**에 놓아야 합니다.

이동 방법(그림 A)

톱을 휴대할 수 있는 위치로 기기를 접습니다. 잠금 핀 **1**을 안쪽으로 누릅니다. 항상 운반용 핸들 **19**를 사용하여 톱을 들고 다니십시오.

잠금 해제(그림 A)

공구의 잠금을 풀고 헤드를 올리려면 모터 쪽 손잡이를 약간 누르면서 잠금 핀 **1**을 밖으로 잡아당깁니다. 그러면 모터 암이 위 쪽으로 돌아갑니다.

장착(그림 A)

! **주의:** 작동 중 예기치 않은 움직임을 방지 위해 공구를 안정적인고 평탄한 미끄러지지 않은 면에 올려 놓아야 합니다.

- 절단기의 베이스와 맞춘 작업면에 구멍을 뚫습니다.
- 베이스의 장착 구멍 **16**과 장착 면의 구멍에 M10 볼트 2개를 끼웁니다. 톱의 대략적인 길이는 장착면 두께에 102 mm를 더한 것과 같아야 합니다.

불꽃 반사대 조절(그림 A)

! **경고:** 뜨거운 화상을 입을 수 있으므로 작동 직후 불꽃 반사대를 만지지 마십시오.

주변에 있는 사람과 물체가 최대한 불꽃이 튀지 않도록 하려면 불꽃 반사대 나사 **2**를 풀고, 불꽃 반사대 **3**를 조정한 다음 나사를 다시 조입니다. 코드가 변형되거나 불꽃에 닿지 않도록 하십시오. 코드가 손상될 수 있습니다.

락오프 트리거 스위치(그림 A)

톱을 켜려면 락오프 레버 **14**를 공구 왼쪽으로 민 다음 락오프 트리거 스위치 **13**를 누르십시오. 스위치가 눌러 있는 동안 톱이 작동합니다. 절단을 하기 전에 날이 최대 작동속도로 돌아갈 수 있도록 합니다. 톱을 끄려면 스위치를 놓습니다. 힘이 완전히 멈출 때까지 손이나 물건을 힘에 닿지 않도록 하십시오. 톱 헤드를 올리기 전에 톱날이 정지하도록 합니다. 스위치를 잠그는 방법은 존재하지 않습니다.

작업물 고정 및 지지(그림 B, C)

- 앵글은 두 측면이 모두 베이스에 맞닿은 상태에서 가장 잘 고정 및 절삭됩니다.
- 작업물 **30**보다 약간 좁은 스페이서 블록 **29**을 사용하면 힘을 조작하기가 수월합니다(그림 B).
- 긴 형태의 작업물은 베이스 상단과 수평이 되도록 블록 **31**을 받쳐야 합니다(그림 C). 절삭된 부분 **32**은 자연스럽게 떨어지도록 해야 힘이 걸리지 않습니다.

바이스 조작(그림 A, D)

바이스에는 빠른 이동 기능이 있습니다. 너무 단단히 조여진 바이스 **6**를 풀려면 크랭크 **8**를 시계 반대 방향으로 1, 2회 돌려 조임 압력을 풉니다. 바이스 레버 **9**를 위로 올립니다. 크랭크 어셈블리를 원하는 만큼 멀리 잡아당깁니다. 바이스를 크랭크 조작 없이 작업물 방향으로 밀어 넣을 수 있습니다. 바이스 레버를 내린 다음 크랭크를 이용하여 작업물에 바이스를 조입니다.

펜스 조작(그림 A, D, E)

! **경고:** 부착물이나 액세서리를 조정, 제거 또는 설치하기 전에 공구를 끄고 코드를 뽑으십시오. 트리거 스위치가 꺼진 위치에 있는지 반드시 확인하십시오.

펜스 **5**는 두 가지 방법으로 조절할 수 있습니다. 즉, 원하는 절삭 각도를 변경하고 펜스와 바이스 사이의 간격을 변경할 수 있습니다.

원하는 절삭 각도를 변경하는 방법

8 mm 육각 키 **7**를 사용하여 펜스 볼트 **15** 2개를 풀거나 (제거하지는 않음). 원하는 각도 표시 라인을 베이스 **4**에 있는 슬롯 라인 **28**과 맞춥니다. 사용하기 전에 양쪽 펜스 볼트를 단단히 조입니다. 더욱 정확한 직각 절삭을 위해 전원을 분리하고 펜스 볼트 2개를 풀 다음 힘이 베이스까지 들어갈 때까지 암을 아래쪽으로 누릅니다. 직각자를 힘에 맞대어 놓고 펜스를 직각자에 맞춥니다. 사용하기 전에 양쪽 펜스 볼트를 단단히 조입니다. 연구 절삭의 경우, 작업물의 두께와 연구 각도에 따라 바이스 **6**가 단단히 물리도록 할 수도 있습니다. 이러한 절삭 작업 시에는 다른 보조 수단(스프링, 바 또는 C-클램프 등)을 이용하여 작업물을 펜스에 고정시켜야 합니다.

휠 제거 및 설치(그림 F, G)

! **경고:** 심각한 신체 부상의 위험을 줄이려면 부착물 또는 액세서리를 조정하거나 제거/설치하기 전에 공구를 끄고 전원에서 공구 플러그를 빼십시오. 휠이 움직이고 있을 때는 어떤 조절 작업도 수행하지 마십시오. 절단기가 전원에 연결된 상태에서는 어떤 조절 작업도 수행하지 마십시오.

! **경고:** 항상 힘을 취급할 때는 장갑을 사용하십시오.

! **경고:** 휠에 충격을 가하지 말고, 떨어뜨렸거나 충격을 받은 휠을 사용하지 마십시오. 깨지거나 변형되거나 손상된 휠을 사용하지 마십시오.

- 스핀들 잠금 장치 **12** 를 누르고 휠 잠금 레버가 만조 **20** 내부의 홈에 걸려 힘을 고정시킬 때까지 휠 **10** 을 손으로 돌립니다. 8mm 육각 키 **7** 로 연마 휠 중앙에서 볼트 **21** 를 시계 반대 방향으로 풀니다. 볼트는 오른쪽 나사입니다.
- 볼트 **21**, 와셔 **22**, 덮개 만조 **23** 및 기존 휠 **10** 을 제거합니다.
- 만조 표면이 깨끗하고 평평해야 합니다. 위의 과정을 반대로 수행하여 새 연마 휠을 설치합니다.
- 안전한 작동을 위해, 볼트 **21** 를 단단히 조여서 연마 휠 **10** 을 내부 **20** 및 외부 만조 **23** 사이에 단단히 고정하십시오. 볼트 **21** 를 지나치게 조이지 마십시오.

! **경고:** 새 연마 휠로 교체할 때 절단기가 작업물의 어느 위치까지 절삭하여 들어가는지 확인하십시오. 손잡이 부분을 완전히 내렸을 때 휠이 작업물 아래쪽 베이스 부분의 구성품이나 구조물까지 절삭할 수 있기 때문입니다.

절삭의 정확성을 높이기 위한 조작 요령

- 휠 자체 무게로 절삭이 이루어지도록 하십시오. 과도한 힘을 가하면 휠이 미끄러져 절삭 효과가 떨어지거나 휘어져 절삭이 부정확해집니다.
- 펜스 각도를 적당하게 조절하십시오.
- 작업물이 베이스에 평평하게 놓이도록 합니다.
- 작업물을 단단히 고정시켜 작업 중 움직이거나 흔들리지 않도록 하십시오.

모터 브러시 검사 및 교체(그림 H, I)

브러시를 검사할 때는 반드시 플러그를 뽑으십시오. 브러시는 정기적으로 마모 상태를 점검해야 합니다. 브러시를 점검하려면 엔드캡 나사 **24** 2개를 풀고 엔드캡 **25** 을 제거합니다. 각 브러시 **26** 를 제거하려면 먼저 섀트 와이어 **27** 단자 연결 플러그를 빼십시오. 그런 다음 조심스럽게 브러시 스프링을 브러시 박스 뒤로 가게 하고 브러시를 제거합니다. 브러시는 브러시 박스에서 자유롭게 미끄러져야 합니다. 브러시가 그림 I와 같이 8 mm까지 마모된 경우, 교체해야 합니다.

각 브러시를 다시 설치하려면, 조심스럽게 스프링을 브러시 박스에서 뒤로 가게 하고, 브러시를 끼운 다음 브러시를 누르면서 브러시 박스를 건드리지 않는지 확인하면서 스프링이 되돌아가게 합니다. 섀트 와이어 단자를 다시 연결한 다음 엔드캡과 나사 2개를 다시 끼웁니다.

유지 보수

DEWALT 전동 공구는 최소한의 유지 보수로 장기간에 걸쳐 작업이 가능하도록 설계되어 있습니다. 만족스러운 연속 작동은 적절한 공구 관리와 정기적인 청소에 따라 그 성능이 달라질 수 있습니다.

! **경고:** 심각한 신체 부상의 위험을 줄이려면 부축물 또는 액세서리를 조정하거나 제거/설치하기 전에 공구를 끄고 전원에서 공구 플러그를 빼십시오. 트리거 스위치가 꺼짐 위치에 있는지 반드시 확인하십시오. 공구가 갑자기 작동하여 부상을 당할 수 있습니다.



윤활방법

공구 전 부분에 폐쇄형 그리스 밀폐 볼 베어링이 사용되었습니다. 이러한 베어링은 절단기 수명이 다할 때까지 윤활 작용을 지속하도록 출고 시 자체 내에 충분한 윤활제를 담고 있습니다.



청소



경고: 통풍구 속이나 주변에 먼지가 쌓여있는 것이 보이면 가능한 한 자주 건조한 공기를 이용하여 메인 하우징에서 먼지를 불어내십시오. 이 절차를 수행할 때에는 승인된 눈 보호 장구 및 승인된 방진 마스크를 착용하십시오.



경고: 공구의 금속 이외 부분을 청소할 때는 용제 등의 강력한 화학약품을 절대 사용하지 마십시오. 그렇지 않으면 이러한 부분에 사용된 재료가 약해질 수 있습니다. 형광에 몰과 순한 비누를 적서 닦아주십시오. 공구 내부에 액체를 넣거나 공구 부품을 액체에 담그는 행동은 절대 금물입니다.

선택 액세서리



경고: DEWALT에서 제공되지 않는 액세서리는 본 제품에 테스트되지 않았으므로 본 제품에서 이러한 액세서리를 사용하면 위험할 수 있습니다. 신체 부상의 위험을 줄이려면 본 제품에 알맞은 액세서리만 사용해야 합니다.

해당 액세서리에 대한 자세한 정보는 판매 대리점으로 문의하십시오. 유기 연마 제품에 대한 안전 규격, EN12413에 따라 4100 rpm 이상 등급의 고강도 타입 1 유기 결합 휠만 사용하십시오.

환경 보호



분리 수거. 이 기호가 표시된 제품과 배터리를 일반 가정용 쓰레기와 함께 처리하면 안 됩니다.

제품과 배터리에는 재활용되거나 재활용되고 고철 자원에 대한 수요를 줄일 수 있는 자재가 포함되어 있습니다. 전기 제품과 배터리는 지역 규정에 따라 재활용하십시오. 자세한 내용은 www.2helpU.com에서 찾아 볼 수 있습니다.

เลื่อยตัด

D28730

ขอแสดงความยินดี!

คุณได้เลือกใช้เครื่องมือจาก DEWALT ด้วยประสบการณ์หลายปีที่ผ่านมาในการพัฒนาผลิตภัณฑ์และนวัตกรรมใหม่ๆ ทำให้ DEWALT เป็นหนึ่งในเครื่องมือไฟฟ้าที่น่าเชื่อถือที่สุดสำหรับผู้ใช้อุปกรณ์ไฟฟ้าระดับมืออาชีพ

ข้อมูลด้านเทคนิค

		D28730
แรงดันไฟฟ้า	โวลต์ _{AC}	220-240
กำลังไฟเข้า	W	2300
ความเร็วขณะไม่มีโหลด	รอบต่อนาที	4000
ความเร็วรอบนอกต่ำสุด แผ่นตัด	ม./วินาที	80
เส้นผ่าศูนย์กลางของแผ่น	มม.	355
รูกกลางแผ่น	มม.	25.4
ความหนาของแผ่นตัด	มม.	3.0
ขนาดเกลียวของแกนหมุน		M10
ประเภทของแผ่นตัดตรง	ไม่ถอยกลับ	
ความสามารถในการตัดขวางที่มุม 90°		
วงกลม	มม.	125
สี่เหลี่ยมจัตุรัส	มม.	115 x 115
สี่เหลี่ยมมุมฉาก	มม.	115 x 130
มุม	มม.	120 x 120
ความสามารถในการตัดขวางที่มุม 45°		
วงกลม	มม.	115
สี่เหลี่ยมจัตุรัส	มม.	98 x 98
สี่เหลี่ยมมุมฉาก	มม.	95 x 105
มุม	มม.	105 x 105
น้ำหนัก	กก.	15.5

คำจำกัดความ: ข้อแนะนำด้านความปลอดภัย

คำจำกัดความด้านล่างอธิบายถึงระดับความรุนแรงของคำแต่ละคำที่ใช้เรียกสัญลักษณ์ต่างๆ โปรดอ่านคู่มือและทำความเข้าใจกับสัญลักษณ์เหล่านี้

! **อันตราย:** หมายถึงสถานการณ์ที่ก่อให้เกิดอันตรายได้อย่างฉับพลัน ซึ่งหากไม่ระวังจะทำให้เสียชีวิตหรือได้รับบาดเจ็บสาหัสได้

! **คำเตือน:** หมายถึงสถานการณ์ที่มีแนวโน้มว่าจะก่อให้เกิดอันตราย ซึ่งหากไม่ระวังสามารถทำให้เกิดอันตรายถึงชีวิตหรือบาดเจ็บสาหัสได้

! **ข้อควรระวัง:** หมายถึงสถานการณ์ที่มีแนวโน้มว่าจะก่อให้เกิดอันตราย ซึ่งถ้าไม่ระวัง อาจทำให้ได้รับบาดเจ็บเล็กน้อยหรือปานกลาง

ข้อสังเกต: หมายถึงการปฏิบัติที่ไม่เกี่ยวข้องกับ การบาดเจ็บส่วนบุคคล ซึ่งหากไม่ระวัง อาจทำให้ทรัพย์สินเสียหาย



แสดงถึงอันตรายจากการถูกไฟฟ้าช็อต



แสดงถึงอันตรายจากการเกิดเพลิงไหม้

คำเตือนเพื่อความปลอดภัยทั่วไป สำหรับการใช้อุปกรณ์ไฟฟ้า



คำเตือน: อ่านคำเตือน ข้อปฏิบัติเพื่อความปลอดภัยทั้งหมด รวมทั้งภาพประกอบและข้อมูลจำเพาะที่ให้มากับเครื่องมือไฟฟ้านี้ การไม่ปฏิบัติตามคำเตือนและข้อปฏิบัติเหล่านี้ อาจทำให้เกิดไฟฟ้าช็อต เกิดอัคคีภัย และ/หรือบาดเจ็บสาหัสได้

โปรดเก็บรักษาคำเตือนและข้อปฏิบัติทั้งหมดนี้ไว้เพื่อการอ้างอิงในภายหลัง

คำว่า "เครื่องมือไฟฟ้า" ในคำเตือน หมายถึงเครื่องมือไฟฟ้า (แบบมีสาย) ที่ทำงานผ่านแหล่งจ่ายไฟหลัก หรือเครื่องมือไฟฟ้า (แบบไร้สาย) ที่ทำงานผ่านแบตเตอรี่

1) ความปลอดภัยในบริเวณที่ทำงาน

- รักษาความสะอาดและจัดให้มีแสงสว่างเพียงพอในบริเวณที่ทำงาน บริเวณที่มีแดดหรือมีของวางระเกะระกะอาจทำให้เกิดอุบัติเหตุได้
- ห้ามใช้เครื่องมือไฟฟ้าในบริเวณที่อาจเกิดการระเบิด เช่น ในสถานที่ที่มีของเหลว แก๊ส หรือฝุ่นละอองที่มีคุณสมบัติไวไฟ เครื่องมือไฟฟ้าจะทำให้เกิดประกายไฟที่อาจทำให้เกิดละอองไฟหรือเปลวไฟขึ้นได้
- ระวังไม่ให้เด็กเล็กและคนเดินผ่านไปมาเข้าใกล้ในขณะที่ใช้งานเครื่องมือไฟฟ้า สิ่งรบกวนอาจทำให้คุณเสียสมาธิได้

2) ความปลอดภัยทางไฟฟ้า

- ปลั๊กไฟของเครื่องต้องเป็นชนิดเดียวกับตัวรับห้ามตัดแปลงปลั๊กไม่ว่าด้วยวิธีใด ห้ามใช้ปลั๊กอะแดปเตอร์ใดๆ กับเครื่องมือไฟฟ้าที่ต่อสายดิน (ลงกราวด์) ปลั๊กที่ไม่มีการดัดแปลงและตัวรับชนิดเดียวกันจะช่วยลดความเสี่ยงจากการเกิดไฟฟ้าช็อต
- หลีกเลี่ยงการสัมผัสพื้นผิวที่ต่อสายดินหรือลงกราวด์ เช่น ท่อ หม้อน้ำ เตาแก๊ส และตู้เย็น มีความเสี่ยงเพิ่มขึ้นที่จะเกิดไฟฟ้าช็อตหากร่างกายเป็นสื่อเชื่อมต่อกับดินหรือลงกราวด์
- อย่าให้เครื่องมือไฟฟ้าถูกฝนหรืออยู่ในสภาพที่เปียกชื้น น้ำที่เข้าเครื่องมือไฟฟ้าจะเพิ่มความเสี่ยงในการเกิดไฟฟ้าช็อต
- ห้ามใช้สายไฟผิดวัตถุประสงค์ ห้ามใช้สายไฟเพื่อการหิ้ว ดึง หรือถอดปลั๊กเครื่องมือไฟฟ้า เก็บสายไฟให้พ้นจากความร้อน น้ำมัน ของมีคม หรือ ชิ้นส่วนที่กำลังเคลื่อนที่ สายไฟที่ชำรุดหรือพันกันเป็นการเพิ่มความเสี่ยงจากการถูกไฟฟ้าช็อต

- e) เมื่อใช้เครื่องมือไฟฟ้านอกอาคาร ให้ใช้สายต่อพ่วงที่เหมาะสมสำหรับการใช้งานนอกอาคาร ใช้สายไฟที่เหมาะสมสำหรับใช้นอกอาคารจะช่วยลดความเสี่ยงต่อการเกิดไฟฟ้าช็อต
- f) หากไม่สามารถหลีกเลี่ยงการใช้เครื่องมือไฟฟ้าในบริเวณที่ชื้นและ/ได้ ให้ใช้แหล่งจ่ายไฟที่มีตัวตัดการทำงานของวงจรเนื่องจากความผิดปกติของกราวด์ (GFCI) การใช้ GFCI จะเป็นการลดความเสี่ยงที่จะถูกไฟฟ้าช็อต

3) ความปลอดภัยส่วนบุคคล

- a) ดึงตัวและมีสมาธิกับสิ่งที่คุณกำลังทำ รวมทั้งใช้สามัญสำนึกในขณะที่กำลังใช้งานเครื่องมือไฟฟ้า ห้ามใช้เครื่องมือไฟฟ้าในขณะที่คุณกำลังเหนื่อยหรือได้รับอิทธิพลจากยา แอลกอฮอล์ หรือการรับประทานยา การขาดความระมัดระวังในการใช้เครื่องมือไฟฟ้าแม้ว่าขณะหนึ่งอาจทำให้บาดเจ็บสาหัสได้
- b) ใช้อุปกรณ์คุ้มครองความปลอดภัยส่วนบุคคล สมุดอุปกรณ์ป้องกันดวงตาเสมอ อุปกรณ์ป้องกัน เช่น หน้ากากกันฝุ่น รองเท้ากันภัยกันลื่น หมวกกันภัย หรืออุปกรณ์ป้องกันเสียงดังที่ใช้ในสภาวะที่เหมาะสมจะช่วยลดอาการบาดเจ็บทางร่างกาย
- c) ปกป้องเครื่องเปิดทำงานโดยไม่ตั้งใจ สวิตช์ต้องอยู่ในตำแหน่งปิดก่อนที่จะเสียบปลั๊กเข้ากับแหล่งจ่ายไฟ และ/หรือ ชุดแบตเตอรี่ หรือก่อนจะยกหรือหิ้วเครื่องมือ การยกเครื่องมือไฟฟ้าในขณะที่นิ้วอยู่ที่สวิตช์ หรือใช้เครื่องมือไฟฟ้าที่สวิตช์เปิดอยู่ อาจทำให้เกิดอุบัติเหตุได้
- d) ถอดกุญแจปรับตั้งหรือประแจออกก่อนเปิดสวิตช์เครื่องมือไฟฟ้า ประแจหรือกุญแจที่เสียบค้างอยู่ในชิ้นส่วนที่หมุนได้ของเครื่องมือไฟฟ้าอาจทำให้ได้รับบาดเจ็บได้
- e) ห้ามยืนเขย่งเท้าขณะใช้เครื่อง ครวยืนในท่าที่เหมาะสมและสมดุลตลอดเวลา เพื่อช่วยในการควบคุมเครื่องมือไฟฟ้าได้ดียิ่งขึ้นในสถานการณ์ที่ไม่คาดคิด
- f) แต่งกายให้เหมาะสม ห้ามสวมเสื้อผ้าหลวมหรือใส่เครื่องประดับ รวบผม ชายเสื้อ และถุงมือให้ห่างจากชิ้นส่วนที่กำลังหมุน เสื้อผ้าที่หลวมหรือยารวม รวบ เครื่องประดับ หรือผมที่ยาวอาจเข้าไปพันกับชิ้นส่วนที่กำลังหมุน
- g) หากมีอุปกรณ์สำหรับดูดและเก็บฝุ่น ต้องตรวจสอบให้แน่ใจว่าได้เชื่อมต่อและใช้งานอุปกรณ์นั้นอย่างเหมาะสม การใช้อุปกรณ์เก็บฝุ่นจะช่วยลดอันตรายที่เกี่ยวข้องกับฝุ่นได้
- h) อย่าให้ความเคยชินจากการใช้งานทำให้คุณประมาทและละเลยการปฏิบัติตามหลักการเพื่อความปลอดภัย การใช้งานโดยไม่ระวังอาจทำให้เกิดการบาดเจ็บสาหัสได้ภายในเวลาเพียงเสี้ยววินาที

4) การใช้งานและการดูแลรักษาเครื่องมือไฟฟ้า

- a) ห้ามฝืนใช้เครื่องมือไฟฟ้า เลือกใช้เครื่องมือไฟฟ้าที่ถูกต้องตรงกับลักษณะการใช้งานของคุณ เครื่องมือไฟฟ้าที่ถูกต้องย่อมทำงานได้ดีกว่าและปลอดภัยกว่าเมื่อใช้งานตามที่คิดที่เครื่องมือได้รับการออกแบบมา

- b) ห้ามใช้เครื่องมือไฟฟ้าถ้าสวิตช์เปิดปิดเครื่องไม่ทำงาน เครื่องมือไฟฟ้าที่ไม่สามารถควบคุมผ่านสวิตช์ได้ ถือว่ามีอันตรายและต้องส่งซ่อม
- c) ถอดปลั๊กของเครื่องมือไฟฟ้าออกจากแหล่งจ่ายไฟและ/หรือแบตเตอรี่ หากถอดได้ ให้ถอดแบตเตอรี่ออกก่อนทำการปรับตั้ง เปลี่ยนอุปกรณ์เสริมหรือจัดเก็บเครื่องมือไฟฟ้า มาตรการเพื่อความปลอดภัยเชิงการป้องกันนี้จะช่วยลดความเสี่ยงในการเคลื่อนเปิดเครื่องไฟฟ้าให้ทำงานโดยไม่ตั้งใจ
- d) เก็บเครื่องมือไฟฟ้าที่ไม่ได้ใช้งานไว้ในพื้นที่ที่แห้งและปลอดภัยในกรณีที่ไม่คุ้นเคยกับเครื่องมือไฟฟ้าหรือคำแนะนำเหล่านี้เป็นผู้ใช้เครื่องมือ เครื่องมือไฟฟ้าจะเป็นอันตรายหากอยู่ในมือผู้ใช้ที่ไม่มีประสบการณ์
- e) บำรุงรักษาเครื่องมือไฟฟ้า ตรวจสอบว่าชิ้นส่วนที่เคลื่อนที่ได้มีการวางไม่ตรงแนวหรือติดขัดหรือไม่ มีชิ้นส่วนที่แตกหัก และสภาพพื้นใดที่อาจส่งผลต่อการทำงานของเครื่องมือไฟฟ้าหรือไม่ หากชำรุดเสียหาย ให้นำเครื่องมือไปส่งซ่อมก่อนนำมาใช้ อุบัติเหตุจำนวนมากเกิดจากการดูแลรักษาเครื่องมือไฟฟ้าไม่ดีพอ
- f) เครื่องมือตัดต้องคมและสะอาดอยู่เสมอ เครื่องมือตัดที่ได้รับการดูแลรักษาอย่างถูกต้องและมีขอบตัดคม จะมีปัญหาติดขัดน้อย และควบคุมได้ง่ายกว่า
- g) ใช้เครื่องมือไฟฟ้า อุปกรณ์เสริม และดอกสว่านของเครื่องมือไฟฟ้า เป็นคน ให้ตรงตามข้อปฏิบัติเหล่านี้ โดยพิจารณาถึงสภาพการทำงานและงานที่ทำเป็นสิ่งสำคัญ การใช้เครื่องมือไฟฟ้าทำงานอื่นนอกเหนือจากที่กำหนดไว้อาจทำให้เกิดอันตรายได้
- h) หมั่นดูแลให้มือจับและพื้นผิวที่จับนั้นแห้ง สะอาด ปราศจากน้ำมันและจาระบี มือจับและผิวสัมผัสที่ลื่นอาจทำให้เกิดการใช้งานที่ไม่ปลอดภัยและทำให้ไม่สามารถควบคุมเครื่องมือในสถานการณ์ฉุกเฉินได้อย่างถูกต้อง

5) การบริการ

- a) ให้ช่างซ่อมที่มีความเชี่ยวชาญเป็นผู้ซ่อมเครื่องมือไฟฟ้า และใช้อะไหล่ของแท้เท่านั้น ซึ่งจะช่วยให้มั่นใจได้ว่าเครื่องมือไฟฟ้ายังมีความปลอดภัยอยู่

คำแนะนำด้านความปลอดภัยสำหรับแท่นตัดไฟเบอร์

1) คำเตือนเพื่อความปลอดภัยสำหรับแท่นตัดไฟเบอร์

- a) ตัวคุณและผู้ที่อยู่ใกล้เคียงต้องออกห่างจากแนวระนาบของแผ่นตัดที่กำลังหมุน ตัวครอบป้องกันนี้จะช่วยปกป้องผู้ทำงานจากชิ้นส่วนของแผ่นตัดที่แตกหัก และการสัมผัสโดนร่างกายของผู้ทำงานโดยไม่ตั้งใจ
- b) ใช้เฉพาะแผ่นตัดเสริมแรงยึดหรือแผ่นตัดเพชรสำหรับเครื่องมือไฟฟ้า การที่อุปกรณ์เสริมสามารถตัดเข้ากับเครื่องมือไฟฟ้าของคุณได้นั้น ไม่ได้รับประกันว่าอุปกรณ์เสริมนั้นจะทำงานอย่างปลอดภัย
- c) ความเร็วตามพิกัดของอุปกรณ์เสริมจะต้องเท่ากับความเร็วสูงสุดที่กำหนดไว้บนเครื่องมือ

ไฟฟ้าเป็นอย่างไร อุปกรณ์เสริมที่ต้องทำงานด้วยความเร็วกว่าที่กีดความเร็วของอุปกรณ์ อาจแตกหักและกระเด็นหลุดออกได้

- d) **ต้องใส่แผ่นตัดสำหรับการใช้งานที่แนะนำเท่านั้น ตัวอย่างเช่น ห้ามใช้ด้านข้างของแผ่นตัดกับงานเจียร** แผ่นตัดแบบขัดมีวัตถุประสงค์เพื่อการเจียรแนวตั้ง แรงดันข้างที่กระทำกับแผ่นเหล่านี้อาจทำให้แผ่นแตกออกได้
- e) **ทุกครั้งให้ใช้หน้าแปลนแผ่นตัดที่ไม่ชำรุดเสียหาย ที่มีเส้นผ่าศูนย์กลางที่ถูกต้องเหมาะสมสำหรับแผ่นตัดที่คุณเลือกใช้** หน้าแปลนแผ่นเจียรที่เหมาะสมจะช่วยรองรับแผ่นเจียรไว้ ดังนั้นจึงลดการแตกหักของแผ่นเจียรที่อาจเกิดขึ้นได้
- f) **เส้นผ่าศูนย์กลางภายนอกและความหนาของอุปกรณ์เสริมต้องอยู่ภายในที่กีดความสามารถของเครื่องมือไฟฟ้า** อุปกรณ์เสริมที่มีขนาดไม่ถูกต้องจะไม่สามารถทำการป้องกันหรือควบคุมได้อย่างเพียงพอ
- g) **ขนาดรอยของแผ่นตัด หน้าแปลน แผ่นรองหลัง หรืออุปกรณ์เสริมอื่นใดต้องเข้ากันได้พอดีกับแกนหมุนของเครื่องมือไฟฟ้า** อุปกรณ์เสริมที่มีขนาดของรูไม่ตรงกับกับสวนติดตั้งของเครื่องมือไฟฟ้าจะทำให้ขาดความสมดุล มีอาการสั่นผิดปกติ และอาจทำให้สูญเสียการควบคุมได้
- h) **ห้ามใช้แผ่นตัดที่ชำรุด ก่อนใช้งานทุกครั้ง ให้ตรวจสอบแผ่นตัดเพื่อหาเศษวัสดุและรอยร้าว ถ้าเครื่องมือไฟฟ้าหรือแผ่นตัดตกลง ให้ตรวจหาการชำรุดเสียหายหรือติดตั้งแผ่นตัดที่ไม่ชำรุด** หลังจากการตรวจสอบและติดตั้งแผ่นตัดแล้ว ตัวคุณและผู้ที่อยู่ใกล้เคียง ต้องออกห่างจากแนวระนาบของแผ่นตัดที่กำลังหมุน และเปิดเครื่องมือไฟฟ้าที่ความเร็วสูงสุดโดยไม่มีภาระโหลดเป็นเวลาหนึ่งนาที โดยปกติแผ่นตัดที่ชำรุดจะแตกออกในระหว่างการทดสอบนี้
- i) **สวมใส่อุปกรณ์คุ้มครองความปลอดภัยส่วนบุคคล ใช้หน้ากากป้องกัน แวนตาบรึกซ์ หรืออุปกรณ์ป้องกันดวงตาอื่นๆ ตามลักษณะการใช้งาน ให้สวมหมวกกันฝุ่น อุปกรณ์ป้องกันเสียงดัง ถุงมือ และผ้ากันเปื้อนที่สามารถป้องกันเศษทรายขัดหรือเศษชิ้นส่วนของชิ้นงานได้ โดยขึ้นอยู่กับความเหมาะสมในการใช้งาน** อุปกรณ์ป้องกันดวงตาต้องสามารถกันเศษชิ้นงานที่ปลิวออกมาซึ่งเกิดจากการทำงานประเภทต่างๆ หน้ากากกันฝุ่นหรือหน้ากากป้องกันต้องสามารถกรองฝุ่นที่เกิดจากการทำงานได้ การอยู่ใกล้เสียงดังมาก เป็นเวลานานอาจทำให้สูญเสียความสามารถในการได้ยิน
- j) **กันผู้ที่อยู่ใกล้เคียงให้ออกห่างจากบริเวณพื้นที่ทำงานในระบะที่ปลอดภัย ผู้ที่เข้ามาในพื้นที่ทำงานต้องสวมใส่อุปกรณ์ป้องกันส่วนบุคคล เศษชิ้นส่วนของชิ้นงานหรือของแผ่นตัดที่แตกหักอาจหลุดกระเด็นออกมา และอาจทำให้ได้รับบาดเจ็บในระยะเกินกว่าพื้นที่ทำงานโดยตรง**
- k) **วางสายไฟให้ห่างจากอุปกรณ์เสริมที่กำลังหมุน** หากคุณสูญเสียการควบคุม สายไฟอาจถูกตัดหรือ

ติดขัด และอาจดึงมือหรือแขนของคุณเข้าไปหาแผ่นตัดที่กำลังหมุนอยู่

- l) **ห้ามสวมใส่คาดข้อมือระบะบายอากาศของเครื่องมือไฟฟ้าเป็นประจำ** พัดลมของมอเตอร์สามารถดูดฝุ่นละอองเข้าไปในตัวเครื่อง และการสะสมของผงโลหะมากเกินไปอาจทำให้เกิดอันตรายทางไฟฟ้าได้
- m) **ไม่ควรใช้เครื่องมือไฟฟ้าใกล้วัสดุไวไฟ** **ไม่ควรใช้เครื่องมือขณะวางอยู่บนพื้นผิววัสดุที่ติดไฟง่าย** เช่น ไม้ ประกายไฟอาจทำให้วัสดุเหล่านี้ติดไฟได้
- n) **ไม่ควรใส่อุปกรณ์เสริมที่ต้องเติมสารหล่อลื่นที่เป็นของเหลว** การใช้น้ำหรือของเหลวอื่นในการหล่อลื่น อาจทำให้ได้รับอันตรายจากไฟฟ้าจนถึงแก่ความตายหรือไฟฟ้าช็อตได้

การติดตั้งและค่าเดือนที่เกี่ยวข้อง

การติดตั้งคือปฏิบัติการที่เกิดขึ้นบนพื้นที่ในไดอะแกรมตัดที่กำลังหมุนที่ถูกหนีบหรือติดขัด การหนีบหรือการติดขัดทำให้แผ่นตัดที่กำลังหมุนเกิดการสั่นอย่างรวดเร็ว ซึ่งอาจทำให้เครื่องตัดที่ไม่สามารถควบคุมได้เกิดการดีดตัวขึ้นใส่ผู้ปฏิบัติงาน ตัวอย่างเช่น ถ้าแผ่นตัดติดขัดหรือถูกหนีบโดยชิ้นงาน ขอบของแผ่นตัดที่กำลังเข้าไปสู่จุดหนีบอาจดันเข้าไปสู่พื้นผิวของวัสดุ ซึ่งจะทำให้แผ่นตัดปีนออกหรือหลุดออก แผ่นตัดยังอาจแตกหักภายใต้สภาวะเหล่านี้อีกด้วย

การดีดกลับเป็นผลจากการใช้งานเครื่องมือไฟฟ้าผิดวิธี และ/หรือขึ้นตอนหรือสภาพการใช้งานไม่ถูกต้อง ซึ่งสามารถหลีกเลี่ยงได้โดยการปฏิบัติตามค่าเดือนที่เหมาะสมตามที่ระบุไว้ด้านล่างนี้

- a) **จับยึดเครื่องมือไฟฟ้าให้แน่นตลอดเวลา และจัดตำแหน่งร่างกายและแขนเพื่อให้สามารถต้านแรงดีดกลับได้** ผู้ปฏิบัติงานสามารถควบคุมแรงดีดกลับขึ้นข้างบนได้ ถ้าทำตามข้อควรระวังที่เหมาะสม
- b) **อย่าให้ร่างกายของคุณอยู่ด้านหลังก่อนหรืออยู่ในแนวเดียวกับแผ่นตัดที่กำลังหมุน** หากมีการดีดกลับเกิดขึ้น เครื่องตัดจะดีดกลับใส่ผู้ปฏิบัติงานได้
- c) **ห้ามติดใบเลื่อยไม้แบบโซ่ ใบเลื่อยเพชรแบบมีร่อง ใบเลื่อยแบบมีฟันที่มีระยะห่างของเส้นรอบวงมากกว่า 10 มม.** ใบเลื่อยแบบนี้มักจะทำให้เกิดการดีดกลับและสูญเสียการควบคุม
- d) **ห้ามทำให้แผ่นตัดเกิดการ "ติดขัด" หรือใช้แรงกดมากเกินไ้** อย่าพยายามตัดลึกมากเกินไป การทำให้แผ่นตัดมีความเครียดมากเกินไปจะเป็นการเพิ่มโหลดและความไวต่อการบิดตัวหรือการดีดขัดของแผ่นตัดในการตัด และมีความเป็นไปได้ที่จะเกิดการดีดกลับหรือการแตกหักของแผ่นตัด
- e) **เมื่อแผ่นตัดติดขัดหรือเมื่อการตัดหยุดชะงักลงด้วยเหตุผลใดๆ ก็ตาม ให้ปิดสวิตช์เครื่องมือไฟฟ้าและจับเครื่องตัดให้อยู่กับที่จนกระทั่งแผ่นตัดหยุดหมุน** อย่าพยายามเลื่อนแผ่นตัดออกจากรอยตัดขณะที่แผ่นตัดกำลังหมุนอยู่ มิฉะนั้นอาจทำให้เกิดแรงดีดกลับได้ ตรวจสอบและทำการแก้ไขข้อขัดข้องของแผ่นตัดที่ติดขัด
- f) **อย่าเพิ่งเริ่มการตัดชิ้นงานอีกครั้ง ให้ปิดเครื่องจนกระทั่งแผ่นตัดทำงานที่ความเร็วเต็มที่แล้วจึงเลื่อนเข้าไปยังรอยตัด** หากเครื่องมือถูกเปิดสวิตซ์

ขณะที่ค้างอยู่ในชิ้นงาน อาจทำให้แผ่นตัดติดขัด
ป็นชิ้นมา หรือติดกลับได้

- g) **รองรับชิ้นงานที่มีขนาดใหญ่เพื่อลดความเสี่ยงที่
แผ่นจะถูกหนีบหรือติดกลับ** ชิ้นงานที่มีขนาดใหญ่มี
แนวโน้มที่จะหย่อนลงเนื่องจากน้ำหนักของตัวชิ้นงาน
เอง สิ่งที่มารองรับต้องวางไว้ใต้ชิ้นงานใกล้แนวตัดและ
ใกล้ขอบของชิ้นงานบริเวณทั้งสองด้านของแผ่นตัด

คำแนะนำเพื่อความปลอดภัยเพิ่มเติม สำหรับเลื่อยตัด

- ในระหว่างการใช้งาน หลีกเลี่ยงการทำให้แผ่นตัดเกิด
การติดตัวหรือใช้งานอย่างไม่เหมาะสม หากกรณีนี้เกิด
ขึ้น ให้หยุดเครื่องมือและตรวจสอบแผ่นตัด
- ห้ามใช้งานเครื่องมือนี้ขณะที่มีผู้ยืนอยู่ในแนวเดียวกับแผ่น
ตัด ห้ามไม่ให้บุคคลอื่นเข้าใกล้บริเวณที่กำลังปฏิบัติงาน
- ระวังเศษชิ้นส่วนที่ตัดและวัสดุที่กำลังตัด ชิ้นส่วนเหล่านั้น
อาจคมและร้อน ปล่อยให้ชิ้นส่วนที่ตัดออกเย็นลงก่อน
ทำการจับต้อง
- ตัวป้องกันประกายไฟจะมีความร้อนในระหว่างการใช้งาน
หลีกเลี่ยงการสัมผัสหรือการปรับตั้งตัวป้องกันประกายไฟ
ในพื้นที่หลังจากการใช้งาน
- ปิดสวิตช์เครื่องมือและรอให้แผ่นตัดหยุดก่อนเลื่อนชิ้น
งานหรือเปลี่ยนแปลงการตั้งค่า
- หลังจากปิดสวิตช์ อย่าพยายามหยุดแผ่นตัดด้วยการกด
ที่ด้านข้างของงาน
- ห้ามใช้สารหล่อเย็นในการตัด ของเหลวเหล่านี้อาจจุด
ติดไฟหรือทำให้ถูกไฟดูดได้
- ตรวจสอบว่ามีภาระรองรับชิ้นงานอย่างถูกต้อง
- ใช้แผ่นตัดที่แนะนำโดยบริษัทผู้ผลิตเท่านั้น อย่าใช้
เครื่องมือจนกว่าจะดูประสงค์ที่กำหนด เช่น อย่าใช้ใบเลื่อย
วงเดือนตัดกิ่งไม้หรือท่อนซุง
- ความเร็วสูงสุดที่ยอมรับได้ของแผ่นตัดต้องเท่ากับหรือ
มากกว่าความเร็วขณะไม่มีภาระโหลดของเครื่องมือที่ระบุ
ไว้บนป้ายชื่อเสมอ
- ห้ามใช้แผ่นตัดที่ไม่สอดคล้องตามขนาดที่ระบุไว้ใน
ข้อมูลทางเทคนิค
- อ่านคำแนะนำการใช้งานที่บริษัทผู้ผลิตแผ่นตัดให้มา
- ตรวจสอบให้แน่ใจว่าเพลาลูกตลับได้รับการติดตั้งอย่าง
ถูกต้องและขันแน่นก่อนการใช้งาน
- ให้เปิดเครื่องทำงานโดยไม่มีภาระโหลดในตำแหน่งที่
ปลอดภัยเป็นเวลาอย่างน้อย 30 วินาที หากมีการสั้น
ค่อนข้างมาก หรือหากมีสิ่งผิดปกติอื่นใดเกิดขึ้น ให้หยุด
เครื่องมือและตรวจสอบเครื่องมือเพื่อหาสาเหตุ
- ห้ามใช้แผ่นตัดเพื่อการเจียรด้านข้าง
- ห้ามใช้ตัดวัสดุคอนกรีต อิฐ กระเบื้อง หรือเซรามิก
- ห้ามใช้ตัดวัสดุไม้ พลาสติค หรือวัสดุสังเคราะห์
- ห้ามใช้ตัดวัสดุเหล็กหล่อ
- อย่าใช้ตัดวัสดุแมกนีเซียม
- อย่าใช้ตัดวัสดุที่มีกระแสไฟฟ้าไหลผ่าน
- ใช้เครื่องมือนี้ในบริเวณที่มีการระบายอากาศเป็นอย่างดี
ห้ามใช้งานเครื่องมือใกล้ช่องเหลวไวไฟ แก๊ส หรือฝุ่น

ละออง ประกายไฟหรือเศษชิ้นส่วนที่ร่อนจากการตัดหรือ
การอาร์กแปร่งถ่านมอเตอร์อาจเผาไหม้วัสดุไวไฟได้

- ทำความสะอาดช่องระบายอากาศอยู่เสมอเมื่อทำงาน
ในสภาพที่มีฝุ่นละออง หากมีความจำเป็นต้องทำความสะอาด
ช่องระบายอากาศ ให้ใช้แปรงขนอ่อนเสมอ และ
อย่าสัมผัสปลั๊กเครื่องมือก่อน
- เก็บแผ่นตัดในบริเวณที่แห้งและพ้นจากมือเด็กเสมอ
- ตรวจสอบชิ้นส่วนที่ชำรุดเสียหาย ก่อนใช้งานเครื่องมือ
ต่อไป ควรตรวจดูตัวครอบป้องกันหรือชิ้นส่วนอื่นที่ได
รับความเสียหายอย่างถาวรเพื่อพิจารณาว่าจะสามารถ
ทำงานได้อย่างถูกต้องตามที่ควรจะเป็นหรือไม่ ตรวจสอบดู
การตรงแนวและการตัดขัดของชิ้นส่วนที่เคลื่อนที่ได้
การแตกหักของชิ้นส่วนต่างๆ การยึดและติดตั้ง ตลอดจน
สภาพอื่นๆ ที่อาจมีผลต่อการทำงานของเครื่องมือ
ตัวครอบป้องกันหรือชิ้นส่วนอื่นที่ชำรุดเสียหายควรจะ
ได้รับการซ่อมแซมหรือเปลี่ยนใหม่ให้เหมาะสม

ความเสี่ยงอื่นๆ ที่ยังมีอยู่

- การใช้งานเครื่องมือเหล่านี้อาจเป็นสาเหตุของความเสี่ยง
ดังต่อไปนี้:
 - การบาดเจ็บจากการสัมผัสชิ้นส่วนที่กำลังหมุน
 - การบาดเจ็บที่เกิดจากการแตกของแผ่นตัด
- ความเสี่ยงเหล่านี้ชัดเจนมากที่สุด:
 - ภายในช่วงเวลาของการใช้งาน
 - ภายในช่วงเวลาที่ยื่นส่วนของเครื่องมือที่กำลังหมุน
- แม้จะปฏิบัติตามข้อกำหนดด้านความปลอดภัยที่เกี่ยวข้อง
และใช้อุปกรณ์ที่รักษาแล้วก็ตาม แต่ก็ไม่สามารถหลีกเลี่ยง
ความเสี่ยงบางอย่างได้ ความเสี่ยงเหล่านี้ ได้แก่
 - ความบกพร่องในการไต่ยืนเสี่ยง
 - ความเสี่ยงจากอุบัติเหตุที่เกิดจากชิ้นส่วนของแผ่นตัด
ที่กำลังหมุนที่ไม่ได้ครอบไว้
 - ความเสี่ยงจากการบาดเจ็บขณะเปลี่ยนแผ่นตัด
 - ความเสี่ยงจากการหนีบนิ้วมือขณะเปิดตัวครอบ

ความปลอดภัยทางไฟฟ้า

มอเตอร์ไฟฟ้าออกแบบมาเพื่อใช้กับแรงดันไฟฟ้าขนาดเดียว
เท่านั้น ต้องตรวจสอบกำลังไฟเพื่อให้ตรงกับแรงดันไฟฟ้า
บนแผ่นแสดงพิกัดเสมอ



เครื่องมือ DEWALT ใช้ระบบขั้วขั้วสองชั้นที่ตรง
ตามมาตรฐาน IEC62841 จึงไม่จำเป็นต้องใช้
สายดิน



คำเตือน: กรณีอุปกรณ์ที่ใช้ไฟ 115 โวลต์ ต้องใช้
งานผ่านหม้อแปลงเดี่ยวแบบมีอุปกรณ์ป้องกัน พร้อม
ทั้งแผ่นสายดินระหว่างขดลวดเหล็กกับขดลวดรอง

ถ้าสายไฟของมอเตอร์ชำรุดเสียหาย ต้องเปลี่ยนเป็นสายไฟ
ที่จัดเตรียมมาเป็นพิเศษซึ่งสั่งซื้อได้จากศูนย์บริการของ
DEWALT

การใช้สายพวง

ในกรณีที่เป็นต้องใช้อสายพวง ให้ใช้สายพวง 3 ขั้วที่ผ่าน
การรับรองและเหมาะสมกับปริมาณไฟเข้าของอุปกรณ์ (ดูที่
ข้อมูลด้านเทคนิค) ขนาดต่ำสุดของสายไฟคือ 1.5 ตร.มม.
ความยาวสูงสุดคือ 30 ม.

เมื่อมีการไขว่ปลอกเม้วนเก็บสายไฟ ให้คลายสายไฟออกจนหมดทุกครั้ง

สิ่งที่อยู่ในบรรจุภัณฑ์

ภายในบรรจุภัณฑ์ประกอบด้วย:

- แท่นตัดไฟเบอร์ด 1 เครื่อง
- เพลาชด 1 ชิ้น
- กุญแจหกเหลี่ยม 1 ชิ้น
- คู่มือการใช้งาน 1 เล่ม

- โปรดตรวจหาร่องรอยความเสียหายของเครื่องมือ ชิ้นส่วนหรืออุปกรณ์เสริม ที่อาจเกิดขึ้นในระหว่างการขนส่ง
- โปรดอ่านและทำความเข้าใจคู่มือเล่มนี้ก่อนการใช้งาน

สัญลักษณ์บนเครื่องมือ

รูปภาพต่อไปนี้จะปรากฏบนเครื่องมือ:



โปรดอ่านคู่มือแนะนำการใช้งานก่อนใช้งาน



สวมอุปกรณ์ป้องกันเสียงดัง



สวมอุปกรณ์ป้องกันดวงตา



ขนาดรูใบเลื่อย



ทิศทางการหมุน

ตำแหน่งของรหัสรุ่นที่ (รูป A)

รหัสรุ่นที่ 18 ซึ่งรวมถึง ปีที่ผลิต จะพิมพ์ไว้บนตัวเครื่องตัวอย่างเช่น:

2019 XX XX
ปีที่ผลิต

คำอธิบาย (รูป A)



คำเตือน: ห้ามปรับแต่งเครื่องมือไฟฟ้าหรือชิ้นส่วนใด ๆ โดยเด็ดขาด เพราะอาจทำให้เครื่องมือชำรุดหรือได้รับบาดเจ็บได้

- | | |
|------------------------|--------------------------|
| 1 สลักล็อค | 11 ตัวครอบป้องกัน |
| 2 สกรูตัวบ่งประกายไฟ | 12 ตัวล็อคแกนหมุน |
| 3 ตัวบ่งประกายไฟ | 13 สวิตช์ล๊อค |
| 4 ฐาน | 14 ก้านล๊อค |
| 5 ฉาก | 15 โบลต์ที่กั้น |
| 6 เครื่องหนีบ | 16 รูยึด |
| 7 กุญแจหกเหลี่ยม 8 มม. | 17 มือจับควบคุมการทำงาน |
| 8 ข้อเหวี่ยง | 18 รหัสรุ่นที่ |
| 9 ระดับเครื่องหนีบ | 19 มือจับสำหรับยกเครื่อง |
| 10 ล้อ | |

วัตถุประสงค์ในการใช้งาน

เลื่อยตัด D28730 ออกแบบมาเพื่อตัดวัสดุเหล็กที่ขึ้นรูปหลากหลายแบบ ได้รับการออกแบบมาสำหรับการใช้กับการ

ขัดที่ต้องใช้แรงช่วยเสริม ไม่ควรใช้ใบตัดแบบเพชรหรือแบบ TCT กับเครื่องนี้

ห้ามใช้งาน หากอยู่ในบริเวณที่เปียกชื้น หรือมีของเหลวไวไฟหรือแก๊สอยู่ในบริเวณดังกล่าว

เลื่อยตัด D28730 เป็นเครื่องมือไฟฟ้าระดับมืออาชีพ

ห้ามปล่อยให้เด็กสัมผัสกับเครื่องมือ ผู้ใช้ที่ไม่มีความรู้

ประสบการณ์มาก่อนต้องได้รับการดูแลในขณะที่ใช้เครื่องมือนี้

- ผู้เยาว์และผู้ที่มีความเชี่ยวชาญ เครื่องมือนี้ไม่ได้มีไว้เพื่อการใช้งานโดยผู้เยาว์หรือผู้ที่มีความเชี่ยวชาญโดยไม่มีการควบคุมดูแล
- เครื่องมือนี้ไม่ได้มีไว้เพื่อการใช้งานโดยบุคคล (ซึ่งรวมถึงผู้เยาว์) ที่มีความบกพร่องทางร่างกาย ทางกรับความรู้สึกร หรือทางจิตประสาท หรือขาดประสบการณ์ ความรู้ และทักษะ เว้นแต่จะได้รับการควบคุมดูแลหรือคำแนะนำการใช้เครื่องมือโดยผู้ที่รับผิดชอบต่อความปลอดภัยของบุคคลเหล่านั้น ห้ามปล่อยผู้เยาว์ไว้กับเครื่องมือนี้ตามลำพัง

การประกอบและการปรับแต่ง



คำเตือน: เพื่อลดความเสี่ยงจากการได้รับบาดเจ็บรุนแรง ต้องปิดเครื่องมือและถอดปลั๊กออกจากแหล่งจ่ายไฟก่อนทำการปรับตั้ง หรือทำการถอด/ติดตั้งอุปกรณ์ยึดติดหรืออุปกรณ์เสริมใดๆ ทุกครั้ง ตรวจสอบให้แน่ใจว่าสวิตช์อยู่ในตำแหน่งปิด (OFF) การเฟลอปเปิดเครื่องโดยไม่ตั้งใจอาจเป็นสาเหตุให้เกิดการบาดเจ็บได้

ความสามารถในการตัด

ช่องเปิดที่กว้าง และจุดหมุนที่สูง ทำให้มีความสามารถในการตัดชิ้นงานขนาดใหญ่ได้หลายชิ้น ใช้กราฟความสามารถในการตัดเพื่อหาขนาดสูงสุดที่สามารถตัดได้ด้วยแผ่นตัดใหม่



ข้อควรระวัง: วัตถุที่มีขนาดใหญ่ เป็นวงกลม หรือมีรูปร่างที่ไม่ปกติ อาจจำเป็นต้องใช้ที่จับเพิ่มเติม ถ้าไม่สามารถยึดได้อย่างแน่นอนขนาดด้วยเครื่องหนีบ



ข้อควรระวัง: ห้ามตัดเมกนินเซียม ไม้อิฐ หรือคอนกรีตด้วยเครื่องมือนี้

รูปร่างชิ้นงาน				
มุมการตัด 90°	A = 125 มม.	A = 115 มม.	115 มม. x 130 มม.	120 มม.
มุมการตัด 45°	A = 115 มม.	A = 98 มม.	95 มม. x 105 มม.	105 มม.

การใช้งาน

วิธีการใช้เครื่อง



คำเตือน: ทำตามคำแนะนำด้านความปลอดภัยและข้อกำหนดที่บังคับใช้เสมอ



คำเตือน: เพื่อลดความเสี่ยงจากการได้รับบาดเจ็บรุนแรง ต้องปิดเครื่องมือและถอดปลั๊กออกจากแหล่งจ่ายไฟก่อนทำการปรับตั้ง หรือทำการถอด/ติดตั้งอุปกรณ์ยึดติดหรืออุปกรณ์เสริมใดๆ ทุกครั้ง ตรวจสอบให้แน่ใจว่าสวิตช์อยู่ในตำแหน่ง

ปิด (OFF) การปล่อยเปิดเครื่องโดยไม่ได้ตั้งใจอาจเป็นสาเหตุให้เกิดการบาดเจ็บได้

ตำแหน่งการจับที่ถูกต้อง (รูป A)



คำเตือน: เพื่อลดความเสี่ยงจากการได้รับบาดเจ็บสาหัส ให้จับเครื่องมือในตำแหน่งที่ถูกต้องดังแสดงในภาพเสมอ



คำเตือน: เพื่อลดความเสี่ยงจากการได้รับบาดเจ็บสาหัส จะต้องจับเครื่องมือให้แน่นทุกครั้ง เพื่อเตรียมพร้อมสำหรับการแรงปฏิกิริยาที่เกิดขึ้นแบบทันทีทันใด

ตำแหน่งของการจับที่ถูกต้องคือ ใช้มือข้างหนึ่งจับที่ตามจับสำหรับใช้งาน 17

การถือ (รูป A)

พนักมือลงไปยังตำแหน่งซึ่งคุณสามารถถือแทนตัดได้ ดันสลับลีด 1 เพื่อให้ลีดคานกลาง จับเครื่องเลื่อยโดยใช้มือจับสำหรับยกเครื่องเสมอ 19

การปลดลีด (รูป A)

หากต้องการปลดลีดเครื่องมือและยกหัวขึ้น ให้ค่อยๆ กดแขนมอเตอร์ แล้วดึงสลับลีด 1 ออก จากนั้นแขนมอเตอร์จะหมุนขึ้น

การติดตั้งอุปกรณ์ (รูป A)



ข้อควรระวัง: ขณะใช้งาน ต้องรองรับเครื่องมือบนพื้นผิวที่มั่นคง ใตระดับ ไม่สั่น เพื่อป้องกันการเคลื่อนที่ไม่คาดคิด

1. เจาะรูบนพื้นผิวชิ้นงานที่ปรับตรงกับฐานของเลื่อยตัด
2. ใส่เม็ดขนาด M10 สองตัวลงผ่านรู 16 ในฐานและผ่านรูในพื้นผิวที่ติดตั้ง ความยาวโดยประมาณของสกรูควรจะเท่ากับความหนาของพื้นผิวที่ติดตั้งบวก 102 มม.

การปรับตัวบังประกายไฟ (รูป A)



คำเตือน: ห้ามจับตัวบังประกายไฟในระหว่างหรือหลังจากใช้งานเสร็จโดยทันทีเนื่องจากตัวบังประกายไฟจะมีความร้อนและอาจไหม้ผิวหนังได้

หากต้องการเปลี่ยนทิศทางประกายไฟให้ออกจากผู้คนและวัสดุที่อยู่ใกล้เคียงให้ดีที่สุด ให้คลายสกรูตัวบังประกายไฟ 2, ปรับตัวบังประกายไฟ 3 จากนั้นไขสกรูกลับให้แน่นอย่าปล่อยให้ชุดสายไฟสัมผัสกับตัวบังประกายไฟ หรือประกายไฟ เนื่องจากอาจทำให้เกิดความเสียหายขึ้นได้

สวิตช์ลีด (รูป A)

หากต้องการเปิดเครื่องเลื่อย ให้ดันก้านลีด 14 ไปทางซ้าย จากนั้นกดสวิตช์ลีด 13 แทนตัดจะทำงานขณะที่กดสวิตช์ปล่อยให้ใบเลื่อยหมุนจนได้ความเร็วเต็มที่ก่อนที่จะทำการตัด ถ้าต้องการปิดแทนตัด ให้ปล่อยสวิตช์ ระวังอย่าให้มือและวัสดุเข้าไปใกล้กับแผ่นตัดจนกว่าจะถึงระยะหยุดนิ่ง รอให้ใบเลื่อยหยุดหมุนก่อนจะยกหัวเลื่อย ไม่มีกลไกสำหรับลีดสวิตช์ให้เปิดตลอด

การหนีบและการรองรับวัสดุ (รูป B, C)

- มุมที่ดีที่สุดในการหนีบและตัด โดยให้ขาทั้งสองยันอยู่กับฐาน

- สามารถใช้บล็อก 29 ช่องว่างที่แคบกว่าชิ้นงาน 30 เล็กน้อยเพื่อเพิ่มการใช้แผ่นตัดได้ (รูป B)
- ต้องรองรับชิ้นงานที่ยาวด้วยบล็อก 31 เพื่อให้ชิ้นงานได้ระดับกับส่วนบนของฐาน (รูป C) ปลายที่ตัดออก 32 ควรสามารถหล่นลงพื้นได้อย่างอิสระ เพื่อหลีกเลี่ยงการติดกับแผ่นตัด

การทำงานของเครื่องหนีบ (รูป A, D)

เครื่องหนีบมีคุณสมบัติในการเลื่อนที่รวดเร็ว หากต้องการคลายเครื่องหนีบ 6 เมื่อยึดอย่างแน่นหนา ให้หมุนข้อเหวี่ยง 8 ทวนเข็มนาฬิกาหนึ่งหรือสองครั้ง เพื่อคลายแรงดันของการหนีบ ยกคานเครื่องหนีบ 9 ขึ้น ดึงส่วนประกอบของข้อเหวี่ยงออกไปไกลตามที่ต้องการ เครื่องหนีบอาจถูกนำไปใช้กับงานโดยไม่ต่อมมีการใช้ข้อเหวี่ยง ลดคานเครื่องหนีบลง จากนั้นไขเครื่องหนีบบนชิ้นงานเมื่อใช้ข้อเหวี่ยง

การทำงานของที่กัน (รูป A, D, E)



คำเตือน: ปิดและถอดปลั๊กเครื่องก่อนทำการปรับใดๆ หรือก่อนถอดหรือใส่อุปกรณ์ยึดติดหรืออุปกรณ์เสริม ตรวจสอบให้แน่ใจว่าสวิตช์อยู่ในตำแหน่งปิด (OFF)

ที่กัน 5 สามารถปรับได้สองทิศทางได้แก่ เมื่อต้องการเปลี่ยนมุมการตัดตามต้องการ และเมื่อต้องการเปลี่ยนระยะห่างระหว่างที่กันและเครื่องหนีบ

การเปลี่ยนมุมการตัดที่ต้องการ

ใช้กฎแจกเหลี่ยมขนาด 8 มม. 7 ที่ใหม่เพื่อคลาย (อย่าถอดออก) โบลต์ที่กันสองตัว 15 จัดแนวเส้นตัวระบุมุมที่ต้องการให้ตรงกับเส้นลีด 28 ในฐาน 4 ไขโบลต์ที่กันทั้งสองตัวให้แน่นก่อนใช้งาน สำหรับการตัดสี่เหลี่ยมที่มีความแม่นยำมากขึ้น ให้ตัดการเชื่อมต่อแหล่งจ่ายไฟ คลายโบลต์ที่กันสองตัว ผลักแขนลงจนกระทั่งแผ่นตัดยึดเข้าไปในฐาน วางแผ่นสี่เหลี่ยมขวางแผ่นเจียร และปรับที่กันเพื่อดันสี่เหลี่ยมไว้ ไขโบลต์ที่กันทั้งสองตัวให้แน่นก่อนใช้งาน เมื่อทำการตัดเพื่อเข้ามุม เครื่องหนีบ 6 อาจยึดชิ้นงานไม่แน่น ขึ้นอยู่กับความหนาของชิ้นงาน และมุมของการเข้ามุม จำเป็นต้องใช้เครื่องมือช่วยอื่นๆ (เช่น สปริง, บาร์ หรือ C-แคลมป์) เพื่อยึดชิ้นงานเข้ากับที่กันในขณะที่ทำการตัดในลักษณะเหล่านี้

การถอดและการติดตั้งแผ่นตัด (รูป F, G)



คำเตือน: เพื่อลดความเสี่ยงจากการได้รับบาดเจ็บรุนแรง ต้องปิดสวิตช์เครื่องมือและถอดปลั๊กออกจากแหล่งจ่ายไฟ ก่อนทำการปรับตั้ง หรือก่อนการถอด/ติดตั้งอุปกรณ์ยึดติดหรืออุปกรณ์เสริมใดๆ ทุกครั้ง อย่าทำการปรับแต่งใดๆ ในขณะที่แผ่นตัดมีการเคลื่อนที่ อย่าทำการปรับแต่งใดๆ ในขณะที่เลื่อยตัดเสียบปลั๊กอยู่กับแหล่งจ่ายไฟ



คำเตือน: ใช้ถุงมือเสมอเมื่อต้องจับแผ่นตัด



คำเตือน: ห้ามสัมผัสแผ่นตัดด้วยมือเปล่า และห้ามใช้แผ่นตัดที่หล่นหรือถูกสัมผัสแล้ว ห้ามใช้แผ่นตัดที่แตก ถูกตัดแปลง หรือชำรุด

1. ผลักตัวล๊อคแกนหมุน 12 และหมุนแผ่นตัด 10 ด้วยมือจนกระทั่งคานล๊อคแผ่นตัดสวมกับสล๊อตด้านในจาน 20 เพื่อล๊อคแผ่นตัด คลายโบลต์ 21 โดยหมุนทวนเข็มนาฬิกาที่ศูนย์กลางของแผ่นตัดด้วยกุญแจหกเหลี่ยมขนาด 8 มม. 7 โบลต์มีเกลียวแบบหมุนขวา
2. ถอดโบลต์ 21, แหวน 22, จานด้านนอก 23 และแผ่นตัดเดิม 10 ออก
3. ให้แน่ใจว่าพื้นผิวของจานสะอาดและเรียบ ดัดตั้งแผ่นตัดใหม่โดยการทำตามขั้นตอนในลำดับย้อนกลับ
4. เพื่อการใช้งานที่ปลอดภัย ให้ขันโบลต์ให้แน่น 21 เพื่อล๊อคแผ่นตัดแบบขั้วให้แน่น 10 ในระหว่างจานด้านใน 20 และด้านนอก 23 แต่อย่าขันแน่นจนเกินไป 21

! **คำเตือน:** ตรวจสอบพื้นผิวของจานที่ตำแหน่งของเลื่อยตัด เมื่อเปลี่ยนแผ่นตัดใหม่ เป็นไปได้ว่าแผ่นตัดอาจสัมผัสกับสิ่งของ หรือโครงสร้างใดๆ ที่ยึดออกมาเหนือพื้นผิวของ (ข้างใต้ฐาน) เมื่อลดระดับแขนลงต่ำสุด

เทคนิคการทำงาน เพื่อการตัดที่มีความแม่นยำมากขึ้น

- ปล่อยให้แผ่นตัดทำการตัดตามปกติ แรงที่มากขึ้นจะทำให้แผ่นตัดมีประสิทธิภาพในการตัดลดลง และ/หรือมีทิศทางเบี่ยงเบนไป ซึ่งเป็นสาเหตุให้การตัดไม่แม่นยำ
- ปรับมุมที่กันอย่างเหมาะสม
- ตรวจสอบให้แน่ใจว่าวงรีสตัดบนฐานที่เรียบ
- ยึดวัสดุอย่างเหมาะสม เพื่อหลีกเลี่ยงการเคลื่อนที่และการสั่น

การตรวจสอบและการเปลี่ยนแปลงถ่านมอเตอร์ (รูป H, I)

อย่าลืมหักปลั๊กเครื่องมือก่อนทำการตรวจสอบแปรปรอง แปรถ่านควรได้รับการตรวจสอบการสึกกร่อนเป็นประจำ หากต้องการตรวจสอบแปรปรองถ่าน ให้คลายสกรูปิดฝาสองตัว 24 และถอดฝา 25 ออก หากต้องการถอดแปรปรองแต่ละชิ้น 26 ก่อนอื่นให้ถอดปลั๊กเชื่อมต่อขั้วปลายสายไฟที่ต่อสลัสน์ 27 จากนั้นค่อยๆ กดสปริงตัวแปรปรองให้ออกมาจากกล่องแปรปรองและถอดแปรปรองออก แปรปรองถ่านควรเลื่อนได้อย่างอิสระในกล่องแปรปรอง ถ้าแปรปรองถ่านสึกเหล็ลต่ำกว่า 8 มม. ดังแสดงในรูป I ควรเปลี่ยนอันใหม่

หากต้องการดัดตั้งแปรปรองแต่ละชิ้นอีกครั้ง ให้ค่อยๆ กดปรองออกจากกล่องแปรปรอง สอดแปรปรองเข้าไปและใส่สปริงเข้าที่เดิม ดูให้แน่ใจว่าสปริงกดอยู่บนตัวแปรปรอง และห้ามแตะต้องกล่องแปรปรอง ต่อขั้วปลายสายไฟแบบสลัสน์อีกครั้ง จากนั้นเปลี่ยนฝาครอบและสกรูสองตัว

การบำรุงรักษา

เครื่องมือไฟฟ้า DEWALT ออกแบบมาเพื่อให้สามารถใช้งานได้ยาวนานต่อเนื่องด้วยการบำรุงรักษาที่น้อยที่สุด การทำงานที่สร้างความสะดวกสบายต่อผู้ใช้จะขึ้นอยู่กับ การดูแลรักษาที่เหมาะสมและการทำความสะอาดอย่างสม่ำเสมอ

! **คำเตือน:** เพื่อลดความเสี่ยงจากการได้รับบาดเจ็บรุนแรง ต้องปิดเครื่องมือและถอดปลั๊กออกจากแหล่งจ่ายไฟก่อนทำการปรับตั้ง หรือทำการถอด/ติดตั้งอุปกรณ์ยึดติดหรืออุปกรณ์เสริมใดๆ ทุกครั้ง ตรวจสอบให้แน่ใจว่าสวิตช์อยู่ในตำแหน่งปิด (OFF) การเคลื่อนเปิดเครื่องโดยไม่ตั้งใจอาจเป็นสาเหตุให้เกิดการบาดเจ็บได้



การหล่อลื่น

ทุกจุดจะใช้ลูกปืนอัดจาระบีแบบปิด ลูกปืนเหล่านี้มีการอัดสารหล่อลื่นมาให้เพียงพอแล้วจากโรงงาน ซึ่งอยู่ได้นานตลอดอายุการใช้งานของแท่นตัดไฟฟ้า



การทำความสะอาด

! **คำเตือน:** หมั่นเป่าสิ่งสกปรกและฝุ่นละอองที่สะสมออกจากตัวเครื่องเป็นประจำด้วยลมแห้ง เนื่องจากสิ่งสกปรกมีสะสมอยู่ภายในและโดยรอบของระบายนอากาศ สวมอุปกรณ์ป้องกันดวงตาและหน้ากากกันฝุ่นที่ได้อัตราฐานในขณะที่ดำเนินการขั้นตอนนี้

! **คำเตือน:** ห้ามใช้สารที่เป็นตัวทำละลายหรือสารเคมีที่มีฤทธิ์กัดกร่อนรุนแรงอื่นๆ ทำความสะอาดชิ้นส่วนของเครื่องมือที่ไม่ใช่โลหะ สารเคมีเหล่านี้อาจกัดกร่อนวัสดุที่ใช้ในชิ้นส่วนเหล่านี้ ใช้เฉพาะผ้าขุบน้ำสบู่อ่อนๆ เท่านั้น อย่าให้มีของเหลวใดๆ เข้าไปในเครื่องมือเด็ดขาด ห้ามจุ่มส่วนใดๆ ของเครื่องมือลงในของเหลวเด็ดขาด

อุปกรณ์เสริม

! **คำเตือน:** เนื่องจากอุปกรณ์เสริมอื่นนอกเหนือจากที่ DEWALT มีจำหน่ายไม่ได้ผ่านการทดสอบร่วมกับผลิตภัณฑ์นี้ จึงอาจก่อให้เกิดอันตรายได้หากใช้ อุปกรณ์เสริมดังกล่าวร่วมกับเครื่องมือนี้ เพื่อเป็นการลดความเสี่ยงที่จะได้รับบาดเจ็บ ให้ใช้อุปกรณ์เสริมเฉพาะที่ DEWALT แนะนำให้ใช้ร่วมกับผลิตภัณฑ์นี้เท่านั้น

โปรดติดต่อตัวแทนจำหน่ายหากต้องการข้อมูลเพิ่มเติมเกี่ยวกับอุปกรณ์เสริมที่เหมาะสม

ใช้แผ่นตัดที่มีการผสมสารอินทรีย์ประเภทที่ 1 ที่มีความแข็งแรงทนทานสูงที่มีความเร็วกว่าหรือเท่ากับ 4100 รอบต่อนาทีเท่านั้นตามคำแนะนำในข้อกำหนดด้านความปลอดภัยสำหรับผลิตภัณฑ์สำหรับการตัดที่มีการผสมสารของ EN12413

การปกป้องสิ่งแวดล้อม



การเก็บรวบรวมแบบคัดแยก ห้ามทิ้งผลิตภัณฑ์และแบตเตอรี่ที่มีสัญลักษณ์นี้รวมกับขยะในครัวเรือนปกติ ผลิตภัณฑ์และแบตเตอรี่ประกอบด้วยวัสดุที่สามารถนำกลับมาใช้ใหม่หรือรีไซเคิลได้ เพื่อลดความต้องการวัตถุดิบ โปรดรีไซเคิลอุปกรณ์ไฟฟ้าและแบตเตอรี่ตามข้อบังคับในท้องถิ่น ดูข้อมูลเพิ่มเติมได้ที่ www.2helpU.com

MÁY CẮT SẮT

D28730

Xin chúc mừng!

Bạn đã chọn thiết bị của DEWALT. Qua nhiều năm kinh nghiệm, những đổi mới và phát triển sản phẩm một cách toàn diện đã khiến DEWALT trở thành một trong những đối tác tin cậy nhất đối với người sử dụng máy điện cầm tay chuyên nghiệp.

Thông số kỹ thuật

		D28730
Điện áp	V _{AC}	220-240
Công suất đầu vào	W	2300
Tốc độ không tải	phút ⁻¹	4000
Đĩa cắt tốc độ cạnh biên tối thiểu	m/giây	80
Đường kính đĩa	mm	355
Đường kính trong đĩa	mm	25,4
Độ dày thân đĩa	mm	3,0
Kích thước ren của trục		M10
Loại đĩa cắt thẳng, không có rãnh		
Công suất cắt ngang ở 90°		
hình tròn	mm	125
hình vuông	mm	115 x 115
hình chữ nhật	mm	115 x 130
hình tam giác	mm	120 x 120
Công suất cắt ngang ở 45°		
hình tròn	mm	115
hình vuông	mm	98 x 98
hình chữ nhật	mm	95 x 105
hình tam giác	mm	105 x 105
Trọng lượng	kg	15,5

Định nghĩa: Hướng dẫn an toàn

Các định nghĩa dưới đây mô tả mức độ nghiêm trọng của từng ký hiệu. Vui lòng đọc hướng dẫn sử dụng và chú ý đến các ký hiệu này.

 **NGUY HIỂM:** Chỉ tình huống nguy hiểm sắp xảy ra, nếu không phòng tránh, sẽ gây tử vong hoặc chấn thương nghiêm trọng.

 **CẢNH BÁO:** Chỉ tình huống nguy hiểm tiềm ẩn, nếu không phòng tránh, có thể gây tử vong hoặc chấn thương nghiêm trọng.

 **THẬN TRỌNG:** Chỉ tình huống nguy hiểm tiềm ẩn, nếu không phòng tránh, có thể gây chấn thương nhẹ hoặc vừa.

LƯU Ý: Chỉ một hành động không liên quan đến chấn thương cá nhân nếu không phòng tránh, có thể gây hư hỏng tài sản.



Biểu thị nguy cơ bị điện giật.



Biểu thị nguy cơ hỏa hoạn.

Cảnh báo chung về an toàn cho máy điện cầm tay



CẢNH BÁO: Đọc kỹ mọi cảnh báo an toàn, hướng dẫn, minh họa và thông số kỹ thuật đi kèm theo máy điện cầm tay này. Việc không tuân theo tất cả các hướng dẫn được liệt kê bên dưới có thể dẫn đến điện giật, cháy và/hoặc chấn thương nghiêm trọng.

GIỮ LẠI MỌI CẢNH BÁO VÀ HƯỚNG DẪN ĐỂ SAU NÀY THAM KHẢO

Thuật ngữ “máy điện cầm tay” trong phần cảnh báo chỉ thiết bị chạy bằng điện nguồn (có dây điện) hoặc thiết bị chạy bằng pin (không có dây điện).

1) An toàn tại nơi làm việc

- Khu vực làm việc phải sạch sẽ và đủ ánh sáng.** Những khu vực bừa bộn hoặc thiếu ánh sáng dễ gây tai nạn.
- Không vận hành máy điện cầm tay trong các môi trường dễ cháy nổ, như các môi trường có chất lỏng, khí hoặc bụi dễ cháy. Máy điện cầm tay tạo ra các tia lửa điện có thể gây cháy bụi hoặc bốc khói.
- Không cho trẻ em và những người quan sát lại gần khi đang vận hành máy điện cầm tay. Những lúc xao lãng có thể khiến bạn mất kiểm soát.

2) An toàn điện

- Phích cắm của máy điện cầm tay phải vừa với ổ cắm.** Không được sửa đổi phích cắm dưới bất kỳ hình thức nào. Không sử dụng các loại phích cắm nối cho máy điện cầm tay có nối đất. Phích cắm nguyên trạng và ổ cắm phù hợp sẽ giúp giảm nguy cơ bị điện giật.
- Tránh tiếp xúc với các bề mặt được nối đất như đường ống, lò sưởi, bếp nướng và tủ lạnh.** Nguy cơ bị điện giật sẽ cao hơn nếu cơ thể bạn nối đất.
- Không để các máy điện cầm tay ngoài trời mưa hoặc ở nơi ẩm ướt.** Nước vào trong máy điện cầm tay sẽ làm tăng nguy cơ bị điện giật.
- Không dùng dây điện cho các mục đích khác.** Tuyệt đối không sử dụng dây điện để mang, kéo hoặc rút phích cắm máy điện cầm tay. Để dây điện cách xa nguồn nhiệt, dầu mỡ, các cạnh sắc hoặc các bộ phận chuyển động. Dây điện bị hỏng hoặc bị vướng sẽ làm tăng nguy cơ bị điện giật.

- e) **Khi vận hành máy điện cầm tay ngoài trời, hãy sử dụng dây nối dài phù hợp để sử dụng ngoài trời.** Sử dụng dây điện phù hợp để sử dụng ngoài trời sẽ giúp giảm nguy cơ bị điện giật.
- f) **Nếu bắt buộc phải vận hành máy điện cầm tay ở nơi ẩm ướt, hãy sử dụng nguồn được bảo vệ bởi thiết bị ngắt mạch khi nối đất lỗi (GFCI).** Sử dụng GFCI giúp giảm nguy cơ bị điện giật.

3) An toàn cá nhân

- a) **Hãy tập trung, chú ý vào những gì bạn đang làm và tình táo khi vận hành máy điện cầm tay. Không sử dụng máy điện cầm tay khi bạn đang mệt hoặc chịu ảnh hưởng của rượu bia, ma túy hoặc chất kích thích.** Chỉ một khoảnh khắc mất tập trung trong khi vận hành máy điện cầm tay cũng có thể dẫn đến chấn thương cá nhân nghiêm trọng.
 - b) **Sử dụng thiết bị bảo hộ cá nhân. Luôn đeo kính bảo hộ.** Thiết bị bảo hộ như mặt nạ chống bụi, giày chống trượt, mũ cứng hoặc thiết bị bảo vệ tai, được sử dụng ở những điều kiện phù hợp, sẽ giúp giảm các chấn thương cá nhân.
 - c) **Tránh vô tình bật máy. Đảm bảo rằng công tắc ở vị trí tắt trước khi nối với nguồn điện và/hoặc pin, khi cầm hoặc mang máy.** Việc cầm máy điện cầm tay khi ngón tay đặt vào công tắc hoặc sạc pin cho máy điện cầm tay khi công tắc đang bật có thể gây tai nạn.
 - d) **Hãy tháo hết khóa điều chỉnh hoặc cờ lê trước khi bật máy điện cầm tay.** Cờ lê hoặc khóa vẫn để ở bộ phận quay của máy điện cầm tay có thể dẫn đến chấn thương cá nhân.
 - e) **Không được với tay. Hãy đứng ở tư thế thích hợp và luôn giữ thăng bằng.** Điều đó giúp kiểm soát máy điện cầm tay tốt hơn trong các tình huống bất ngờ.
 - f) **Mặc quần áo phù hợp. Không mặc quần áo rộng hoặc đeo đồ trang sức. Giữ cho tóc, quần áo và găng tay tránh xa các bộ phận chuyển động.** Quần áo rộng, đồ trang sức hoặc tóc dài có thể bị mắc vào các bộ phận chuyển động.
 - g) **Nếu các thiết bị được cung cấp để kết nối các phương tiện hút hoặc gom bụi, phải đảm bảo những thiết bị này được kết nối và sử dụng đúng cách.** Sử dụng thiết bị gom bụi có thể giảm các nguy cơ liên quan đến bụi.
 - h) **Không nên tự mãn vì đã dùng thành thạo máy mà bỏ qua các nguyên tắc an toàn của máy.** Một hành động bất cẩn cũng có thể gây ra thương tích nghiêm trọng trong tích tắc.
- b) **Không sử dụng máy điện cầm tay nếu công tắc không bật và tắt được.** Những máy điện cầm tay không điều khiển được bằng công tắc đều rất nguy hiểm và cần phải được sửa chữa.
 - c) **Rút phích cắm khỏi nguồn điện và/hoặc tháo pin ra, nếu có thể tháo rời, khỏi máy điện cầm tay, trước khi thực hiện các điều chỉnh, thay đổi phụ kiện hoặc cất giữ máy điện cầm tay.** Các biện pháp an toàn phòng ngừa đó giúp giảm nguy cơ khởi động máy điện cầm tay một cách tình cờ.
 - d) **Bảo quản các máy điện cầm tay không sử dụng xa tầm tay trẻ em và không cho phép những người không quen với máy điện cầm tay hoặc những hướng dẫn này vận hành máy điện cầm tay.** Máy điện cầm tay sẽ rất nguy hiểm khi được sử dụng bởi những người chưa được huấn luyện.
 - e) **Bảo trì máy điện cầm tay. Kiểm tra các bộ phận di chuyển xem có bị lắp lệch hoặc kẹt không, các bộ phận có bị vỡ không và bất kỳ tình trạng nào khác có thể ảnh hưởng đến việc vận hành máy điện cầm tay. Nếu máy điện cầm tay bị hỏng, hãy sửa chữa trước khi sử dụng.** Rất nhiều tai nạn xảy ra do các máy điện cầm tay được bảo trì kém.
 - f) **Đảm bảo các thiết bị cắt luôn sắc và sạch sẽ.** Các máy cắt được bảo trì đúng cách với các cạnh cắt sắc sẽ ít bị kẹt hơn và dễ điều khiển hơn.
 - g) **Sử dụng máy điện cầm tay, các phụ kiện và mũi khoan, v.v. theo hướng dẫn này, chú ý đến các điều kiện làm việc và công việc cần thực hiện.** Sử dụng máy điện cầm tay sai mục đích có thể gây nguy hiểm.
 - h) **Giữ các tay cầm và bề mặt cầm nắm luôn khô ráo, sạch sẽ và không dính dầu mỡ.** Các tay cầm và bề mặt cầm nắm trơn trượt không cho phép xử lý và kiểm soát máy an toàn trong những tình huống bất ngờ.

5) Bảo dưỡng

- a) **Hãy để nhân viên bảo dưỡng có chuyên môn tiến hành bảo dưỡng máy điện cầm tay cho bạn và chỉ sử dụng các bộ phận thay thế chính hãng.** Điều này giúp đảm bảo độ an toàn của máy điện cầm tay đó.

Hướng dẫn an toàn cho máy cắt

1) Cảnh báo an toàn cho máy cắt

- a) **Đảm bảo bạn và những người quan sát đứng cách xa mép của đĩa cắt đang quay.** Vành chắn giúp bảo vệ người vận hành khỏi mảnh vụn của đĩa cắt bị vỡ và tránh vô tình tiếp xúc với đĩa cắt.
- b) **Chỉ sử dụng đĩa cắt cốt thép đính bảm hoặc đĩa cắt kim cương cho máy điện cầm tay này.** Mặc dù có thể lắp phụ kiện vào máy điện cầm tay của bạn, nhưng điều đó không đảm bảo nó sẽ vận hành an toàn.

- c) **Tốc độ định mức của phụ kiện tối thiểu phải bằng với tốc độ tối đa được ghi trên máy điện cầm tay.** Các phụ kiện chạy nhanh hơn tốc độ định mức của chúng có thể vỡ và văng ra xa.
- d) **Chỉ sử dụng đĩa cho các ứng dụng được khuyến nghị.** Ví dụ: không mài bằng cạnh của đĩa cắt. Đĩa mài được sử dụng để mài cạnh biên; lực bên tác dụng vào các đĩa mài này có thể làm cho đĩa mài bị vỡ.
- e) **Luôn sử dụng mặt bích đĩa cắt còn tốt - có đường kính phù hợp với đĩa cắt đã chọn.** Mặt bích đĩa mài phù hợp sẽ đỡ được đĩa mài, do đó làm giảm nguy cơ vỡ đĩa.
- f) **Đường kính ngoài và độ dày của phụ kiện phải nằm trong định mức kích cỡ của máy điện cầm tay.** Các phụ kiện có kích cỡ không chính xác không thể được bảo vệ hoặc kiểm soát thích đáng.
- g) **Kích cỡ tâm của đĩa cắt và mặt bích phải vừa khít với trục của máy điện cầm tay.** Các đĩa cắt và mặt bích có lỗ tâm không khớp với vòng gá của máy điện cầm tay sẽ gây mất cân bằng, rung quá mức và có thể gây mất kiểm soát.
- h) **Không sử dụng đĩa cắt đã hỏng.** Trước khi sử dụng, hãy kiểm tra xem đĩa cắt có bị nứt và có các mảnh vụn không. Nếu máy điện cầm tay hoặc đĩa cắt bị rơi, hãy kiểm tra xem đĩa cắt có bị hỏng không và lắp lại đĩa cắt chưa bị hỏng. Sau khi kiểm tra và lắp đĩa cắt, bạn và những người quan sát nên đứng tránh xa mép của đĩa cắt đang quay và chạy máy điện cầm tay ở tốc độ không tải tối đa trong một phút. Các đĩa cắt bị hỏng thường sẽ vỡ thành từng mảnh trong thời gian chạy thử này.
- i) **Đeo thiết bị bảo hộ cá nhân.** Tùy thuộc vào mục đích sử dụng, có thể dùng tấm che mặt, kính bảo hộ hoặc kính an toàn. Nếu có thể, đeo mặt nạ chống bụi, thiết bị bảo vệ tai, găng tay và tạp dề công nhân có khả năng cản các mảnh vỡ của phôi gia công hoặc mảnh vụn mài nhỏ. Dụng cụ bảo vệ mắt phải có khả năng cản các mảnh vụn văng ra được tạo ra từ nhiều thao tác khác nhau. Mặt nạ chống bụi hoặc khẩu trang phải có khả năng lọc các hạt sinh ra trong quá trình vận hành. Tiếp xúc với tiếng ồn cường độ cao trong thời gian dài có thể gây giảm thính lực.
- j) **Đảm bảo những người quan sát luôn cách khu vực làm việc một khoảng cách an toàn.** Mọi người đi vào khu vực làm việc đều phải đeo thiết bị bảo hộ cá nhân. Các mảnh vụn phôi gia công hoặc đĩa cắt vỡ có thể văng ra và gây chấn thương ngay trong khu vực vận hành.
- k) **Đặt dây điện cách xa phụ kiện đang quay.** Nếu bạn mất kiểm soát, dây điện có thể bị cắt hoặc bị vướng vào và bàn tay hoặc cánh tay của bạn có thể bị cuốn vào đĩa cắt đang quay.
- l) **Thường xuyên vệ sinh các lỗ thông khí của máy điện cầm tay.** Quạt của động cơ có thể hút bụi bên trong vỏ máy và để bột kim loại tích lũy quá nhiều có thể gây ra nguy hiểm về điện.
- m) **Không vận hành dụng cụ điện cầm tay gần các vật liệu dễ cháy.** Không vận hành máy điện cầm tay khi đặt trên bề mặt dễ cháy, như gỗ. Tia lửa có thể làm các vật liệu này bốc cháy.
- n) **Không sử dụng các phụ kiện cần có chất làm mát dạng lỏng.** Sử dụng nước hoặc chất làm mát dạng lỏng khác có thể dẫn đến bị điện giật.

Lực giật lại và các cảnh báo liên quan

Lực giật lại là phản lực bất ngờ của đĩa cắt bị kẹt hoặc bị vướng. Tình trạng kẹt hoặc vướng có thể làm đĩa cắt đang quay dừng nhanh, do đó thiết bị cắt bị mất kiểm soát sẽ bị ép bật lên về phía người vận hành.

Ví dụ: nếu đĩa mài bị vướng hoặc kẹt vào phôi gia công, cạnh của đĩa mài đang tiến vào điểm kẹt có thể cắm sâu vào bề mặt của vật liệu khiến cho đĩa này lên hoặc văng ra. Đĩa mài cũng có thể bị vỡ trong điều kiện này.

Lực giật lại là kết quả của việc sử dụng sai máy điện cầm tay và/hoặc quy trình hoặc điều kiện vận hành không chính xác và có thể tránh được bằng cách thực hiện các biện pháp phòng ngừa thích hợp như được trình bày bên dưới.

- a) **Cầm chắc máy điện cầm tay đồng thời định vị người và tay để bạn có thể cản được lực giật lại.** Người vận hành có thể kiểm soát lực đẩy ngược nếu thực hiện đúng các biện pháp đề phòng.
- b) **Không đứng thẳng hàng với đĩa cắt đang quay.** Nếu có lực giật ngược, thiết bị cắt sẽ bị đẩy bật về phía người vận hành.
- c) **Không lắp xích cưa, lưỡi khắc gỗ, đĩa cắt kim cương được phân đoạn có khoảng cách ngoài vi lớn hơn 10 mm hoặc lưỡi cưa có răng.** Những lưỡi cưa này thường xuyên tạo ra lực giật lại và gây mất kiểm soát.
- d) **Không "kẹp chặt" đĩa cắt hoặc tác dụng lực quá lớn.** Không cố tạo ra vết cắt quá sâu. Ấn đĩa quá mạnh sẽ tăng lực tải và dễ làm xoắn hoặc kẹt đĩa vào vết cắt cũng như có thể gây ra lực giật lại hoặc vỡ đĩa.
- e) **Khi đĩa cắt bị kẹt hoặc ngừng cắt vì bất cứ lý do nào, hãy tắt công cụ điện và giữ nguyên thiết bị cắt cho đến khi đĩa cắt dừng hẳn.** Tuyệt đối không cố rút đĩa cắt ra khỏi vết cắt khi đĩa còn đang chuyển động, nếu không có thể làm phát sinh lực giật lại. Kiểm tra và tiến hành khắc phục để loại bỏ nguyên nhân gây kẹt đĩa.

- f) **Không bắt đầu lại hoạt động cắt trên phôi gia công. Hãy đợi đĩa đạt tốc độ tối đa và cẩn thận đặt lại vào vết cắt.** Đĩa có thể bị kẹt, nảy lên hoặc giật lại nếu máy điện cầm tay được khởi động lại trên phôi gia công.
- g) **Đỡ các phôi gia công quá cỡ để giảm thiểu nguy cơ kẹt đĩa cắt và lực giật lại.** Phôi gia công lớn có xu hướng lún xuống dưới do trọng lượng của chính nó. Phải đặt các tấm đỡ bên dưới cả hai cạnh phôi gia công, gần đường xẻ và gần mép của tấm gia công.

Các cảnh báo an toàn khác cho Máy cắt sắt

- Khi vận hành, tránh để đĩa cắt nảy lên hoặc tác động mạnh vào đĩa. Nếu trường hợp này xảy ra, hãy dừng máy và kiểm tra đĩa cắt.
- Không vận hành công cụ khi đang đứng thẳng hàng với đĩa cắt. Yêu cầu người khác tránh xa khu vực làm việc.
- Cẩn thận các vụn cắt và vật liệu đang cắt. Chúng có thể nóng và có cạnh sắc. Để nguội các bộ phận đã cắt trước khi tiến hành xử lý.
- Tấm chắn tia lửa sẽ nóng lên trong khi sử dụng. Tránh chạm vào hoặc điều chỉnh tấm chắn tia lửa điện ngay sau khi vận hành.
- Tắt công cụ và chờ cho đĩa cắt dừng lại trước khi di chuyển phôi gia công hoặc thay đổi thiết lập.
- Sau khi tắt máy, tuyệt đối không có dừng đĩa cắt bằng cách ép vào cạnh đĩa.
- Không sử dụng dung dịch cắt. Dung dịch cắt có thể bắt lửa hoặc gây nguy cơ điện giật.
- Hãy kiểm tra xem phôi gia công đã được đỡ theo cách phù hợp hay chưa.
- Chỉ sử dụng đĩa cắt theo khuyến nghị của nhà sản xuất. Không sử dụng máy cho mục đích không theo thiết kế; ví dụ, không sử dụng lưỡi cưa tròn để cưa cành cây hoặc thân cây.
- Tốc độ cho phép tối đa của đĩa cắt phải luôn bằng hoặc lớn hơn tốc độ không tải của máy, như được nêu trên biển thông số.
- Không sử dụng đĩa cắt không phù hợp với các kích thước được nêu trong **Thông số kỹ thuật**.
- Đọc kỹ hướng dẫn vận hành do nhà sản xuất đĩa cung cấp.
- Đảm bảo rằng đĩa mài được lắp chặt và đúng cách trước khi sử dụng.
- Để máy chạy không tải ở nơi an toàn trong ít nhất 30 giây. Nếu máy bị rung mạnh hoặc các lỗi khác, hãy dừng máy và kiểm tra để xác định nguyên nhân.
- Không sửa dụng đĩa cắt để mài cạnh.
- Không cắt bê tông, gạch, ngói hoặc đồ sứ.
- Không cắt gỗ, nhựa hoặc vật liệu tổng hợp.

- Không cắt gang.
- Tuyệt đối không cắt magiê.
- Không được cắt vật liệu có điện.
- Vận hành máy này ở khu vực thoáng khí. Không vận hành máy gần chất lỏng dễ cháy, khí ga hoặc bụi. Tia lửa hoặc mặt giữa nóng do cắt hoặc hàn hồ quang chói than động cơ có thể khiến các vật liệu này bốc cháy.
- Thường xuyên vệ sinh các khe thông gió khi làm việc trong điều kiện nhiều bụi. Luôn sử dụng bàn chải mềm nếu cần vệ sinh các khe; chú ý rút phích cắm của máy trước.
- Luôn bảo quản đĩa cắt ở nơi khô ráo và được bảo vệ cẩn thận, tránh xa tầm tay trẻ em.
- Kiểm tra các bộ phận bị hỏng. Trước lần sử dụng máy tiếp theo, cần kiểm tra kỹ vành chắn hoặc bộ phận khác bị hỏng nhằm xác định xem máy có hoạt động đúng và thực hiện đúng chức năng thiết kế hay không — kiểm tra các bộ phận chuyển động xem có bị lắp lệch hoặc kẹt không, các bộ phận có bị vỡ không và bất kỳ tình trạng nào khác có thể ảnh hưởng đến việc vận hành máy. Vành chắn hoặc bộ phận khác bị hỏng phải được sửa chữa và thay thế phù hợp.

Các nguy cơ khác

- Các nguy cơ sau có thể phát sinh trong quá trình sử dụng những máy này:
 - chấn thương do chạm vào các bộ phận quay.
 - chấn thương do đĩa cắt bị vỡ.
- Những nguy cơ sau rất dễ xảy ra:
 - trong phạm vi vận hành
 - trong phạm vi của các bộ phận của máy đang quay
- Cho dù áp dụng các quy định an toàn liên quan và thực hiện các thiết bị an toàn, bạn cũng không thể tránh khỏi một số nguy cơ khác. Chúng bao gồm:
 - Suy giảm thính lực.
 - Nguy cơ xảy ra tai nạn do các phần hờ của đĩa cắt đang quay gây ra.
 - Nguy cơ chấn thương khi thay đĩa cắt.
 - Nguy cơ kẹp ngón tay khi mở vành chắn.

An toàn điện

Động cơ điện được thiết kế để sử dụng tại một mức điện áp duy nhất. Luôn kiểm tra nguồn điện có tương ứng với điện áp trên biển thông số định mức hay không.



Dụng cụ DEWALT này đã được cách điện kép theo tiêu chuẩn IEC62841; do vậy không cần dây nối đất.



CẢNH BÁO: Các thiết bị 115 V phải được vận hành qua máy biến áp cách điện an toàn có lưới tiếp đất giữa bó dây chính và bó dây phụ.

Nếu dây cấp điện bị hỏng, phải thay bằng dây mới được cung cấp riêng tại cơ sở bảo dưỡng của DEWALT.

Sử dụng dây điện nối dài

Nếu cần dùng dây điện nối dài, hãy sử dụng loại dây 3 lõi được chấp nhận phù hợp với công suất đầu vào của máy này (xem phần **Thông số kỹ thuật**). Kích thước dây dẫn tối thiểu là 1,5 mm²; chiều dài tối đa là 30 m.

Khi sử dụng tang dây, luôn trải hết dây ra.

Thiết bị trong hộp

Hộp sản phẩm bao gồm:

- 1 Máy cắt sắt
- 1 Đĩa mài
- 1 Khóa đầu lục giác
- 1 Hướng dẫn sử dụng
- Kiểm tra máy, các bộ phận hoặc phụ kiện xem có bị hư hỏng do quá trình vận chuyển hay không.
- Dành thời gian đọc kỹ và hiểu rõ hướng dẫn sử dụng trước khi vận hành máy.

Ký hiệu trên máy

Trên máy có các ký hiệu sau:



Đọc kỹ hướng dẫn sử dụng trước khi dùng.



Mang thiết bị bảo vệ tai.



Đeo kính bảo hộ.



Đường kính trong



Chiều quay

Vị trí mã ngày (Hình A)

Mã ngày **18**, bao gồm cả năm sản xuất, được in trên vỏ máy.

Ví dụ:

2019 XX XX

Năm sản xuất

Mô tả (hình A)



CẢNH BÁO: Không sửa đổi máy điện cầm tay hay bất kỳ bộ phận nào của máy. Việc sửa có thể làm hỏng máy điện cầm tay hoặc gây chấn thương cá nhân.

- | | |
|--------------------------|----------------------------|
| 1 Chốt khóa | 8 Tay quay |
| 2 Vít tẩm chắn tia lửa | 9 Cần ê-tô |
| 3 Tẩm chắn tia lửa | 10 Đĩa |
| 4 Chân đế | 11 Vành chắn |
| 5 Tẩm chắn | 12 Khóa trục chính |
| 6 Ê-tô | 13 Công tắc khởi động khóa |
| 7 Khóa đầu lục giác 8 mm | 14 Cần khóa |

15 Bu-lông tẩm chắn

18 Mã ngày

16 Lỗ lắp

19 Tay cầm vận chuyển

17 Cần điều khiển

Mục đích sử dụng

Máy cắt sắt D28730 được thiết kế để cắt các loại vật liệu thép có hình dạng khác nhau. Máy được thiết kế để chỉ sử dụng với các sản phẩm mài gắn chắc, được gia công. Không nên sử dụng lưỡi TCT hoặc kim cương cùng với thiết bị này.

KHÔNG sử dụng máy ở những nơi ẩm ướt hoặc có chất lỏng hoặc khí dễ cháy.

Máy cắt sắt D28730 là một máy điện cầm tay chuyên nghiệp.

KHÔNG để trẻ em tiếp xúc với máy. Cần phải có người giám sát khi máy này được vận hành bởi người chưa có kinh nghiệm.

- **Trẻ em và người không đủ sức khỏe.** Thiết bị này không được thiết kế cho trẻ em hoặc người không đủ sức khỏe sử dụng mà không có sự giám sát.
- Không cho phép những người (bao gồm cả trẻ em) bị suy giảm năng lực thể chất, trí tuệ hoặc cảm giác, hay người thiếu kinh nghiệm, kiến thức hoặc kỹ năng sử dụng máy điện cầm tay này, trừ khi có sự giám sát của người chịu trách nhiệm về vấn đề an toàn của họ. Tuyệt đối không được để trẻ em một mình với sản phẩm này.

LẮP RÁP VÀ ĐIỀU CHỈNH



CẢNH BÁO: Để giảm nguy cơ chấn thương cá nhân nghiêm trọng, hãy tắt máy và ngắt kết nối khỏi nguồn điện trước khi thực hiện bất kỳ điều chỉnh nào hoặc tháo/lắp các đồ gá hoặc phụ kiện. Đảm bảo công tắc khởi động ở vị trí OFF. Việc vô tình khởi động có thể gây chấn thương.

Công suất cắt

Khe hở ê-tô và điểm chốt xoay cao khiến máy có thể cắt phiôi gia công với nhiều kích thước khác nhau. Sử dụng biểu đồ công suất cắt để xác định tổng kích thước tối đa mà một đĩa mới có thể thực hiện cắt.



THẬN TRỌNG: Có thể cần thêm các phương tiện gá kẹp đối với các vật cỡ lớn, hình tròn hoặc hình dạng khác thường nếu không thể giữ chặt bằng ê-tô.



THẬN TRỌNG: KHÔNG DÙNG DỤNG CỤ NÀY ĐỂ CẮT MAGIÊ, GỖ, GẠCH HOẶC BÊ TÔNG.

Hình dạng phối gia công				
Góc cắt 90°	A = 125 mm	A = 115 mm	115 mm x 130 mm	120 mm
Góc cắt 45°	A = 115 mm	A = 98 mm	95 mm x 105 mm	105 mm

VẬN HÀNH

Hướng dẫn sử dụng



CẢNH BÁO: Luôn tuân theo các hướng dẫn và quy tắc hiện hành về an toàn.



CẢNH BÁO: Để giảm nguy cơ chấn thương cá nhân nghiêm trọng, hãy tắt máy và ngắt kết nối khỏi nguồn điện trước khi thực hiện bất kỳ điều chỉnh nào hoặc tháo/lắp các đồ gá hoặc phụ kiện. Đảm bảo công tắc khởi động ở vị trí OFF. Việc vô tình khởi động có thể gây chấn thương.

Vị trí tay phù hợp (Hình A)



CẢNH BÁO: Để giảm nguy cơ chấn thương cá nhân nghiêm trọng, Luôn để tay ở vị trí phù hợp như trong hình vẽ.



CẢNH BÁO: Để giảm nguy cơ chấn thương cá nhân nghiêm trọng, luôn giữ chặt tay để tránh trường hợp bị giật lại đột ngột.

Vị trí tay phù hợp yêu cầu một tay đặt lên cần điều khiển 17.

Cách cầm (hình A)

Uốn máy xuống vị trí bạn có thể cầm cửa. Ấn chốt khóa 1 để khóa tay cầm máy. Luôn cầm vào tay cầm khi mang máy 19.

Mở khóa (hình A)

Để mở khóa máy và nâng đầu lên, ấn nhẹ tay gạt động cơ và kéo chốt khóa 1 ra. Sau đó tay gạt động cơ sẽ xoay lên.

Lắp (Hình A)



THẬN TRỌNG: Phải đỡ máy trên bề mặt bằng phẳng, ổn định, không trơn trượt để tránh chuyển động không mong muốn khi vận hành.

1. Khoan các lỗ xuyên qua bề mặt phải thẳng với bề mặt cắt sát.
2. Lắp hai bu-lông M10 xuyên qua các lỗ gắn 16 trong bề mặt và các lỗ trên bề mặt lắp ráp. Chiều dài xấp xỉ của vít phải bằng độ dày của bề mặt lắp ráp cộng với 102 mm.

Điều chỉnh tấm chắn tia lửa (hình A)



CẢNH BÁO: Không chạm vào tấm chắn tia lửa hoặc ngay sau khi vận hành, do tấm chắn nóng và có thể gây bỏng da.

Để tránh tia lửa bắn vào những người và vật liệu xung quanh, nối lỏng vít tấm chắn tia lửa 2 ra, điều chỉnh tấm chắn tia lửa 3 và sau đó siết chặt vít lại. Không để dây điện tiếp xúc với tấm chắn hoặc tia lửa vì có thể làm hỏng dây.

Công tắc khởi động khóa (Hình A)

Để bật máy, gạt cần khóa 14 sang trái, sau đó bấm công tắc khởi động khóa 13. Máy sẽ chạy khi bấm công tắc. Để cánh quay đến tốc độ vận hành tối đa trước khi cắt. Để tắt máy, nhả công tắc. Giữ cho tay và vật liệu cách xa đĩa

cho tới khi đĩa dừng lại. Để cánh dừng hẳn trước khi nâng đầu máy lên. Không có các quy định về khóa công tắc khởi động.

Kẹp và đỡ vật liệu (Hình B, C)

- Các góc được kẹp và cắt bằng cách đặt các góc đỡ dựa vào bề mặt.
- Có thể sử dụng khối đệm 29 nhẹ hơn một chút sao với phôi gia công 30 để tăng hiệu quả sử dụng đĩa (Hình B).
- Phải đỡ phôi gia công dài bằng một khối 31 để phôi gia công cao bằng đỉnh bề mặt (Hình C). Đầu cắt 32 phải có thể rơi xuống tự do để tránh dính vào đĩa.

Vận hành ê-tô (Hình A, D)

Ê-tô có đặc tính di chuyển nhanh. Để nhả ê-tô 6 khi đang được kẹp chặt, hãy vận tay quay 8 ngược chiều kim đồng hồ một hoặc hai lần để giảm lực kẹp. Nâng cần ê-tô 9 lên. Kéo tay quay ra theo mong muốn. Có thể đẩy ê-tô vào phôi gia công và không cần lắp tay quay. Hạ cần ê-tô xuống, sau đó vận ê-tô vào phôi gia công bằng cách dùng tay quay.

Vận hành tấm chắn (Hình A, D, E)



CẢNH BÁO: Tắt và rút nguồn máy trước khi điều chỉnh, tháo hoặc lắp đồ gá hoặc phụ kiện. Đảm bảo công tắc khởi động ở vị trí OFF.

Tấm chắn 5 có thể được điều chỉnh theo hai cách: điều chỉnh góc cắt mong muốn và điều chỉnh khoảng cách giữa tấm chắn và ê-tô.

Điều chỉnh góc cắt mong muốn

Sử dụng khóa đầu lục giác 8 mm 7 được cung cấp để nối lỏng (không tháo) hai bu-lông tấm chắn 15. Lắp bộ phận chỉ báo góc mong muốn khớp với khe 28 trên bề mặt máy 4. Siết chặt cả hai bu-lông tấm chắn trước khi sử dụng. Để cắt hình vuông chính xác hơn, ngắt nguồn điện, nối lỏng hai bu-lông tấm chắn, đẩy tay gạt xuống cho tới khi đĩa đi hết bề mặt. Đặt phôi gia công hình vuông sát vào đĩa và điều chỉnh tấm chắn theo phôi gia công hình vuông. Siết chặt cả hai bu-lông tấm chắn trước khi sử dụng. Khi cắt vật, ê-tô 6 có thể không kẹp chặt tùy vào độ dày của phôi gia công và góc cắt. Các máy phụ trợ khác (như lò xo, thước thanh hoặc kẹp chữ C) sẽ cần thiết để cố định phôi gia công với tấm chắn khi tiến hành cắt trong các trường hợp này.

Tháo lắp đĩa (Hình F, G)



CẢNH BÁO: Để giảm nguy cơ chấn thương cá nhân nghiêm trọng, hãy tắt máy và ngắt điện trước khi thực hiện bất kỳ điều chỉnh nào hoặc tháo/lắp các đồ gá hoặc phụ kiện. Không được điều chỉnh khi đĩa đang chuyển động. Không được điều chỉnh khi máy cắt sắt đang cắm vào nguồn điện.



CẢNH BÁO: Luôn đeo găng tay khi xử lý đĩa.

! **CẢNH BÁO:** Không va đập vào đĩa và không sử dụng đĩa đã bị rơi hoặc bị va đập. Không sử dụng đĩa bị mẻ, biến dạng hoặc hư hỏng.

1. Ấn khóa hãm trục **12** và quay đĩa **10** bằng tay cho tới khi cần khóa đĩa khớp vào khe ở mặt bích trong **20** để khóa đĩa. Nới lỏng bu-lông **21** ngược chiều kim đồng hồ ở tâm của đĩa mài bằng khóa đầu lục giác 8 mm **7**. Bu-lông có ren thuận.
2. Tháo bu-lông **21**, vòng đệm **22**, mặt bích ngoài **23** và đĩa cũ **10**.
3. Đảm bảo bề mặt mặt bích sạch và phẳng. Lắp đĩa mài mới theo các bước ngược lại ở trên.
4. Để vận hành an toàn, siết chặt bu-lông **21** để cố định đĩa mài **10** giữa mặt bích trong **20** và mặt bích ngoài **23**. Không được siết bu-lông **21** quá chặt.

! **CẢNH BÁO:** Kiểm tra bề mặt gia công sao cho máy cắt sắt đứng yên khi thay đĩa cắt mới. Đĩa cắt có thể tiếp xúc với **CÁC VẬT HOẶC CẤU TRÚC LỚN HƠN** bề mặt gia công (nhỏ hơn bề máy) khi hạ hết tay gạt xuống.

Mẹo vận hành để cắt chính xác hơn

- Để đĩa cắt tiến hành cắt. Dùng lực quá mạnh sẽ khiến đĩa cắt quá nhanh, làm giảm hiệu quả cắt và/hoặc đĩa bị lệch dẫn tới cắt không chính xác.
- Điều chỉnh góc tằm chắn hợp lý.
- Đảm bảo vật liệu được đặt phẳng trên bề máy.
- Kẹp vật liệu cho phù hợp để tránh bị di chuyển hay rung.

Kiểm tra và thay thế chổi than động cơ (Hình H, I)

ĐẢM BẢO RÚT PHÍCH CÂM CỦA DỤNG CỤ TRƯỚC KHI KIỂM TRA CHỔI THAN. Chổi than phải được kiểm tra thường xuyên xem có bị mòn hay không. Để kiểm tra chổi than, tháo vít ở hai đầu nắp **24** và tháo nắp **25**. Để tháo từng chổi than **26**, trước tiên rút đầu nối cực dây mắc rẽ **27**. Sau đó gạt lò xo chổi than ra khỏi hộp chổi than và tháo chổi than một cách cẩn thận. Chổi than cần phải trượt ra do được trong hộp chổi than. Nếu chổi mòn chỉ còn 8 mm như trong hình I thì cần thay chổi.

Để lắp lại từng chổi than, cần thận gạt lò xo ra khỏi hộp chổi than, lắp chổi than và gạt lò xo về vị trí cũ, đảm bảo lò xo ép trên chổi than và không chạm vào hộp chổi than. Kết nối lại cực dây mắc rẽ, sau đó thay nắp và hai vít.

BẢO TRÌ

Máy điện cầm tay của DeWALT được thiết kế để vận hành trong thời gian dài và ít phải bảo trì nhất. Dụng cụ vận hành liên tục theo ý muốn tùy thuộc vào việc bảo quản máy đúng cách và vệ sinh thường xuyên.

! **CẢNH BÁO:** Để giảm nguy cơ chấn thương cá nhân nghiêm trọng, hãy tắt máy và ngắt kết nối khỏi nguồn điện trước khi thực hiện bất kỳ điều chỉnh nào hoặc tháo/lắp các đồ gá hoặc phụ kiện. Đảm bảo công tắc khởi động ở vị trí OFF. Việc vô tình khởi động có thể gây chấn thương.



Tra dầu

Luôn sử dụng vòng bi loại khít và được tra dầu. Những vòng bi này được tra dầu tại xưởng để duy trì tuổi thọ của máy cắt sắt.



Vệ sinh

! **CẢNH BÁO:** Thường xuyên thổi bụi bẩn khỏi vỏ máy khi thấy bám bụi xung quanh các khe thông gió. Đeo kính bảo hộ và mặt nạ chống bụi được phê duyệt khi thực hiện quy trình này.

! **CẢNH BÁO:** Tuyệt đối không sử dụng các dung môi và hóa chất mạnh để vệ sinh các bộ phận không làm bằng kim loại của máy. Các hóa chất này có thể làm tổn hại đến các nguyên vật liệu sử dụng trong các bộ phận này. Chỉ sử dụng khăn được làm ẩm bằng nước và xả phòng có tính tẩy nhẹ. Tuyệt đối không để chất lỏng lọt vào bên trong máy; không được ngâm các bộ phận của máy vào chất lỏng.

Phụ kiện tùy chọn

! **CẢNH BÁO:** Do các phụ kiện, không phải loại phụ kiện do DeWALT cung cấp, chưa được kiểm nghiệm với sản phẩm này nên việc sử dụng các phụ kiện đó với sản phẩm này có thể gây nguy hiểm. Để giảm nguy cơ chấn thương, chỉ được sử dụng các phụ kiện do DeWALT khuyến nghị cho sản phẩm này.

Hỏi ý kiến đại lý để biết thêm thông tin về các phụ kiện phù hợp.

Chỉ sử dụng các loại đĩa cắt gắn chắc hữu cơ Loại 1 có độ bền cao, có tốc độ tối thiểu 4100 vòng/phút trở lên phù hợp với tiêu chuẩn EN12413, các yêu cầu an toàn dành cho sản phẩm mài gắn chắc.

Bảo vệ môi trường



Thu gom riêng. Không được vứt bỏ sản phẩm và pin có ký hiệu này cùng với rác thải sinh hoạt thông thường.

Sản phẩm và pin chứa vật liệu có thể thu hồi hoặc tái chế giúp giảm nhu cầu về vật liệu thô. Vui lòng tái chế sản phẩm điện và pin theo quy định của địa phương. Thông tin thêm có sẵn tại www.2helpU.com.

